



This data sheet interacts with
GFX Catalogues

## GFX Hygienic Design

GFX Hygienic Design comprises of track system variations that are suitable for use with the Beckhoff “HD” hygienic design XTS motors and magnets. There are two systems which are applicable to differing customer needs:

### Cleandown - GFX-CD-1TL

Suitable for “wet” cleaning and uses a structure that is very similar to a standard GFX, but modified to fit the HD (Hygienic Design) motors. It has applications in pharmaceutical, food and other processes where the system requires wet cleaning with benign liquids, wet wipes etc to remove surface contamination. Fasteners are grade A2 stainless steel.

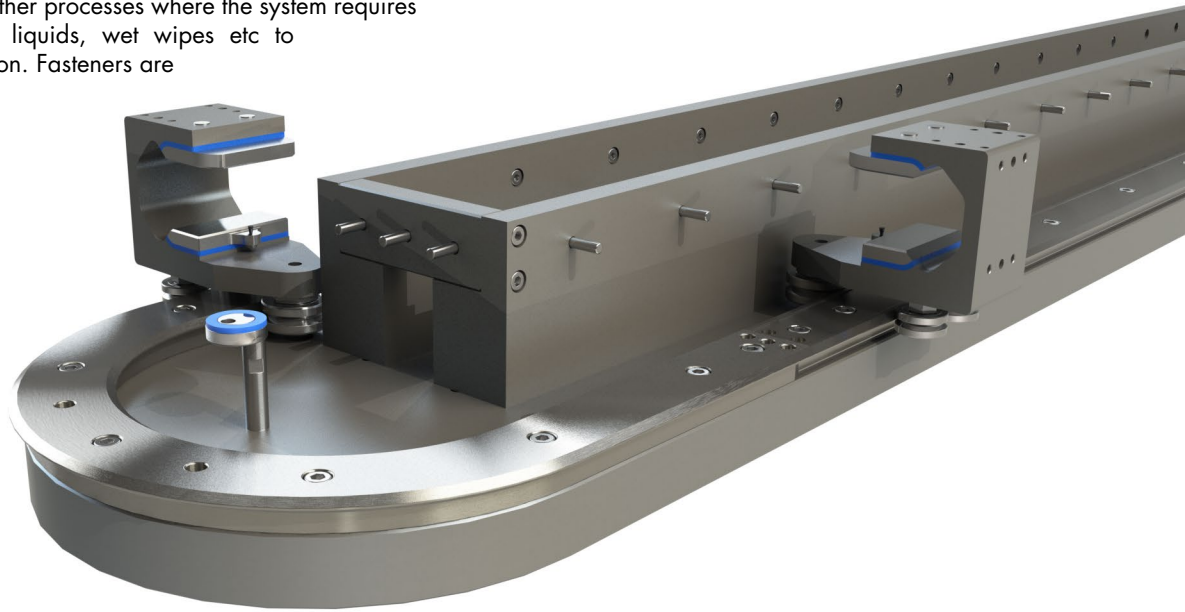

### Washdown - GFX-WD-1TL

Designed for cleaning in place (CIP) operations that include foaming agents, hot washing and pressure washing. The construction allows complete access to all surfaces, pooling traps are removed, joints between all components are sealed and the bearings are protected against lubricant egress and “flushing” with a solid cover and labyrinth seals. All fasteners are sealed and designed to minimize trap and ease cleaning processes.

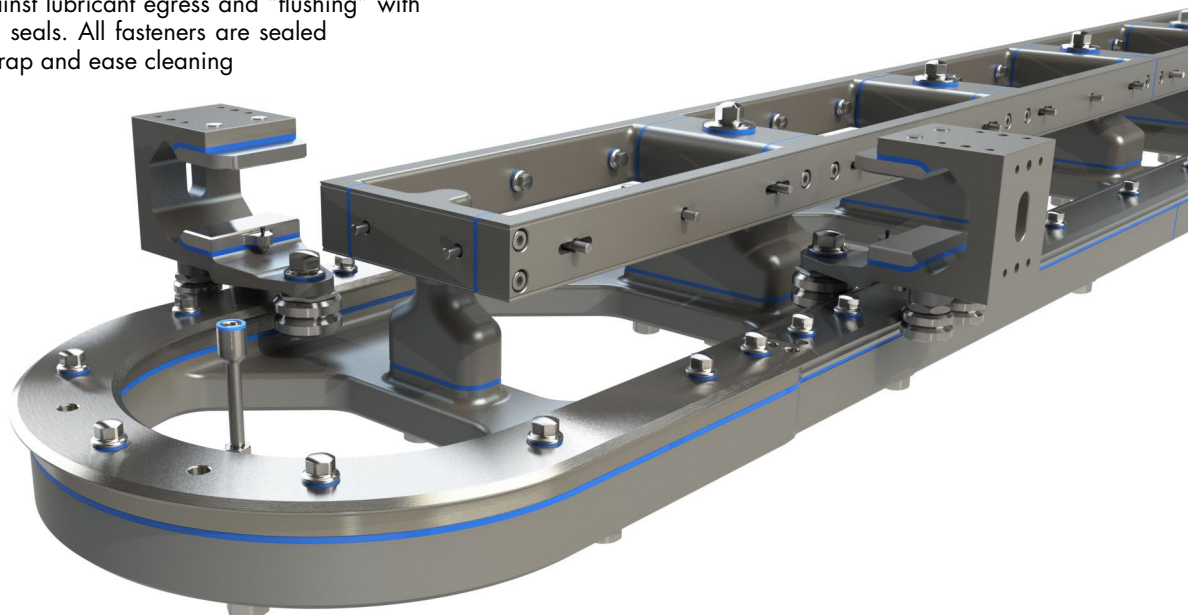

Both systems use aluminium structural components, in both the frame and the mover body. These components are hard anodized and the process reinforced with highly wear and chemical resistant additives. All slide and bearing components are martensitic stainless steel, offering good corrosion resistance and hardness suitable for bearing surfaces and consequent long service life.

## Technical Information

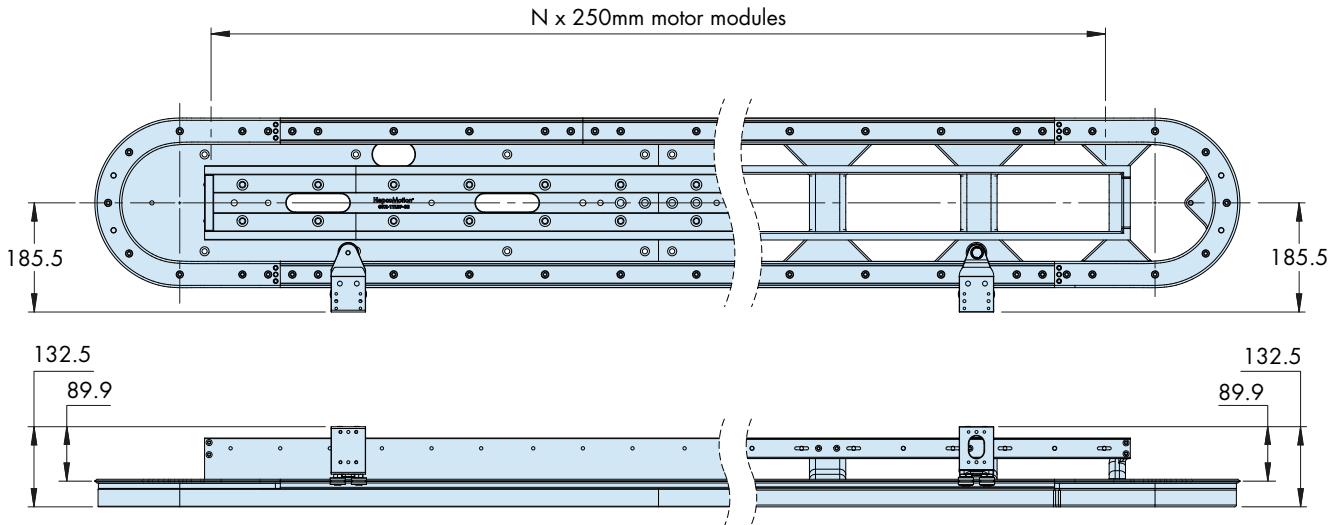

### Cleandown

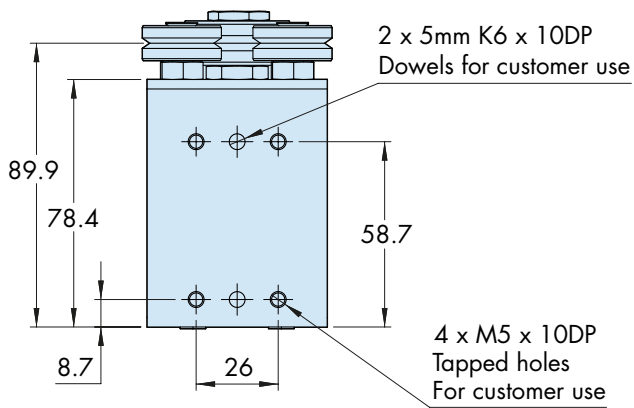

### Washdown

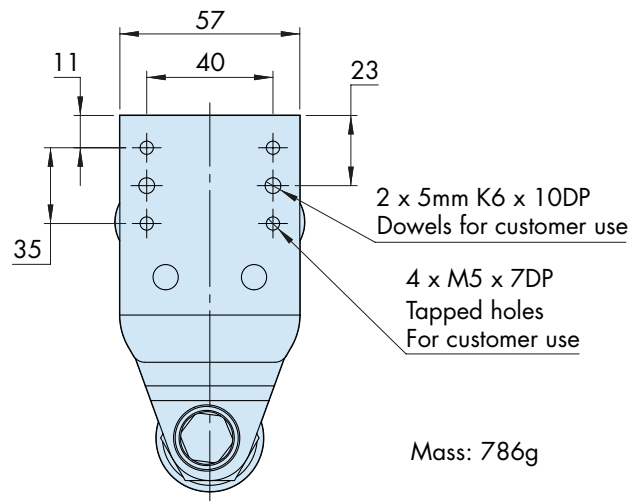
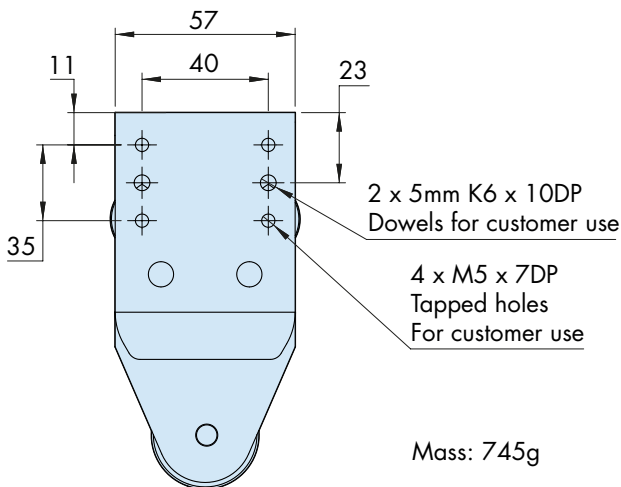
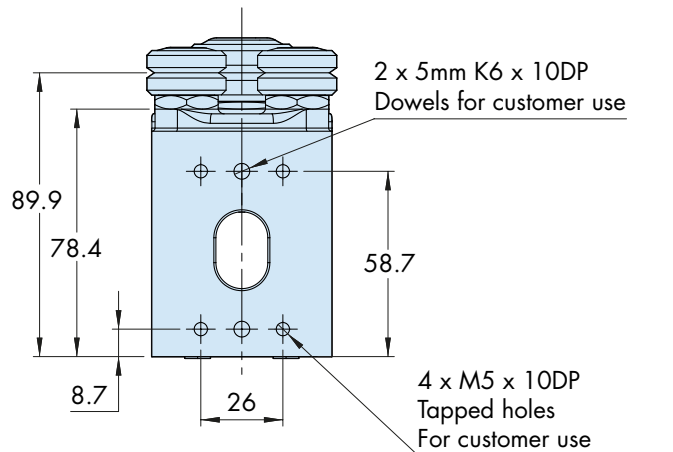

### Notes:

1. Cleandown movers are fitted as standard with stainless steel AS (Axial Stiffness) bearings. Washdown movers are fitted with double row sealed hygienic bearings. Contact Hepco's technical department for more information.

# GFX Hygienic Design

## Integration

Cleandown is similar to a standard GFX track system and uses the same base plate geometry therefore integrations processes are broadly the same. Washdown however should be designed in to the equipment in such a way that the system will drain and access for cleaning is maintained.

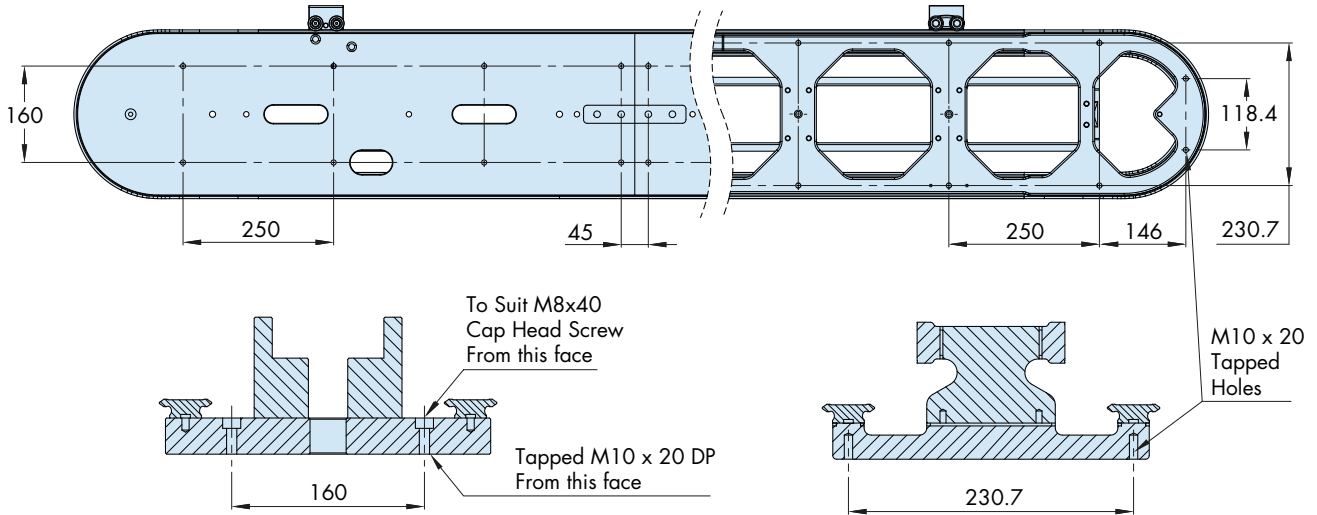

## Additional Information

- GFX is a guidance system for Beckhoff's XTS linear transport system.
- Detailed CAD data available on request please contact Hepco's Technical Sales department for more information.
- Integration of the Beckhoff Hygienic motors is more complex than the standard XTS motor including special seals and components that require special assembly techniques
- Hepco GFX Hygienic design is suitable for aseptic applications

## Ordering Details

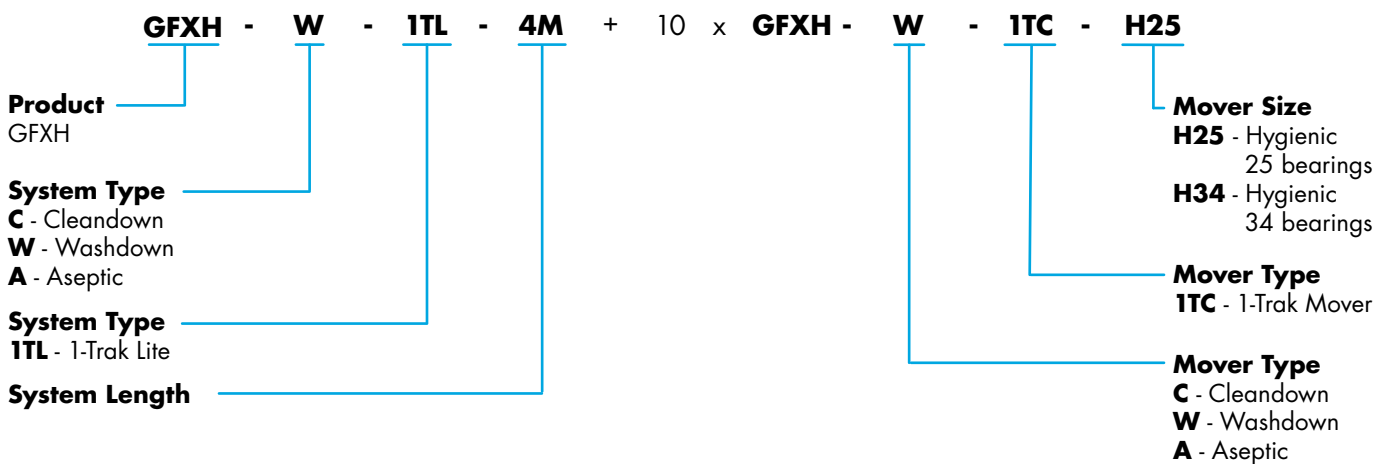

HepcoMotion®, Lower Moor Business Park,  
Tiverton Way, Tiverton, Devon, England EX16 6TG  
Tel: +44 (0) 1884 257000  
E-mail: sales@hepcotion.com

[www.HepcoMotion.com](http://www.HepcoMotion.com)