

HLG

Corrosion Resistant
Options Available

HepcoMotion®

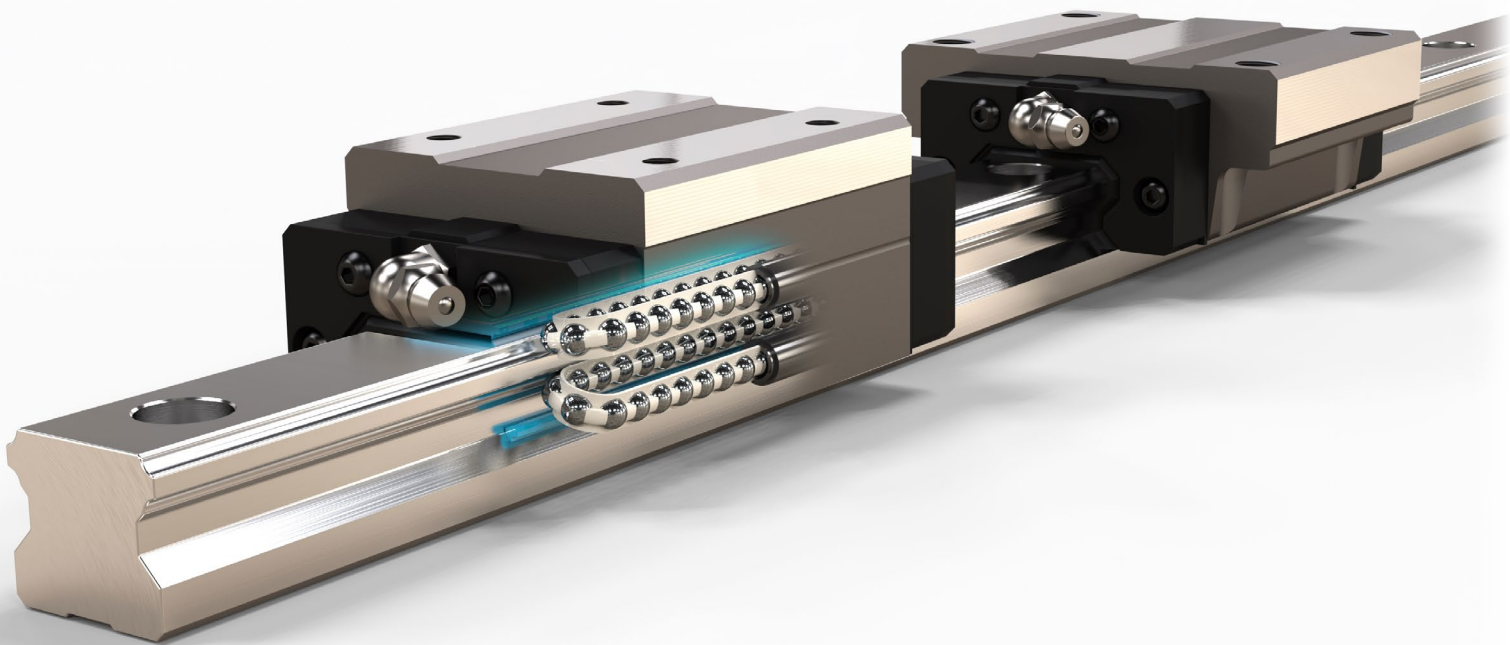





















ADVANCED LINEAR SOLUTIONS



HLG

HEPCO LINEAR BALL GUIDES

HepcoMotion.com

HLG Linear Ball Guides			
Introduction	1	Block options	2
Rail options	3		
 HLG...RN/RNA Standard Rectangular Series Standard	4	 HLG...RL/RLA Standard Rectangular Series Long	4
 HLG...FN/FNA Standard Flanged Series Standard	6	 HLG...FL/FLA Standard Flanged Series Long	6
 HLGS...RC/RCA Compact Rectangular Series Short	8	 HLGS...RN/RNA Compact Rectangular Series Standard	8
 HLGS...FC/FCA Compact Flanged Series Short	9	 HLGS...FN/FNA Compact Flanged Series Standard	9
 HLG...RCSA Spacer Chain Rectangular Series Short	10	 HLG...RNSA Spacer Chain Rectangular Series Standard	10
 HLG...FCSA Spacer Chain Flanged Series Short	11	 HLG...FNFA Spacer Chain Flanged Series Standard	11
 HLGS...RCSA Spacer Chain Compact Rectangular Series Short	12	 HLGS...RNSA Spacer Chain Compact Rectangular Series Standard	12
 HLGS...FCSA Spacer Chain Compact Flanged Series Short	13	 HLGS...FNFA Spacer Chain Compact Flanged Series Standard	13
MLG Linear Ball Guides			
Introduction	14	Block and rail options	15
 MLG...C Miniature Standard Series Short	16	 MLG...N Miniature Standard Series Medium	16
 MLG...L Miniature Standard Series Long	16		
 MLGB...C/CE Miniature Wide Series Short	17	 MLGB...N/NE Miniature Wide Series Medium	17
 MLGB...L/LE Miniature Wide Series Long	17		
HLG/MLG Brake	18	Lubrication	20
Surface Treatment	21	Sealing	21
Precision and Preload Data	22	Friction and Static Load Capacity	24
Life Calculation	25	Installation Data	26
Rail Joining Details	27	Ordering Details	28

The HLG range of recirculating ball guides brings a new dimension to linear motion by offering smooth, low friction movement with high rigidity and load capacity, at competitive prices.

The range is available in standard sizes, and offers the unique bleed lubrication system option, which enables blocks to be re-greased through the rail, making it easy to set up an automatic lubrication facility.

HLG Standard, Compact, and Spacer Chain Series ball guides have four rows of balls with a 45° loading angle between the rolling elements and raceways, giving equal vertical and horizontal load capacities. The steel balls are configured in an X-style arrangement, which provides tolerance to deviations in parallelism and height variation in systems with multiple linear guides.

HLG blocks have an effective sealing arrangement at both ends and along the sides. This prevents serious dirt ingress and maximises retention of grease for track lubrication.

For manual applications, there is the option of a fitted brake that enables blocks to be firmly locked into position.

The HLG range also includes the **MLG Miniature Series**, in standard and wide block versions (see [14](#)). These high precision units also include the brake option facility. Manufactured as standard in stainless steel, MLG will be an ideal match for any scientific or medical application, or installations where space is limited.

Available across all precision grades and preloads, HLG offers a durable, high performance linear guide solution.

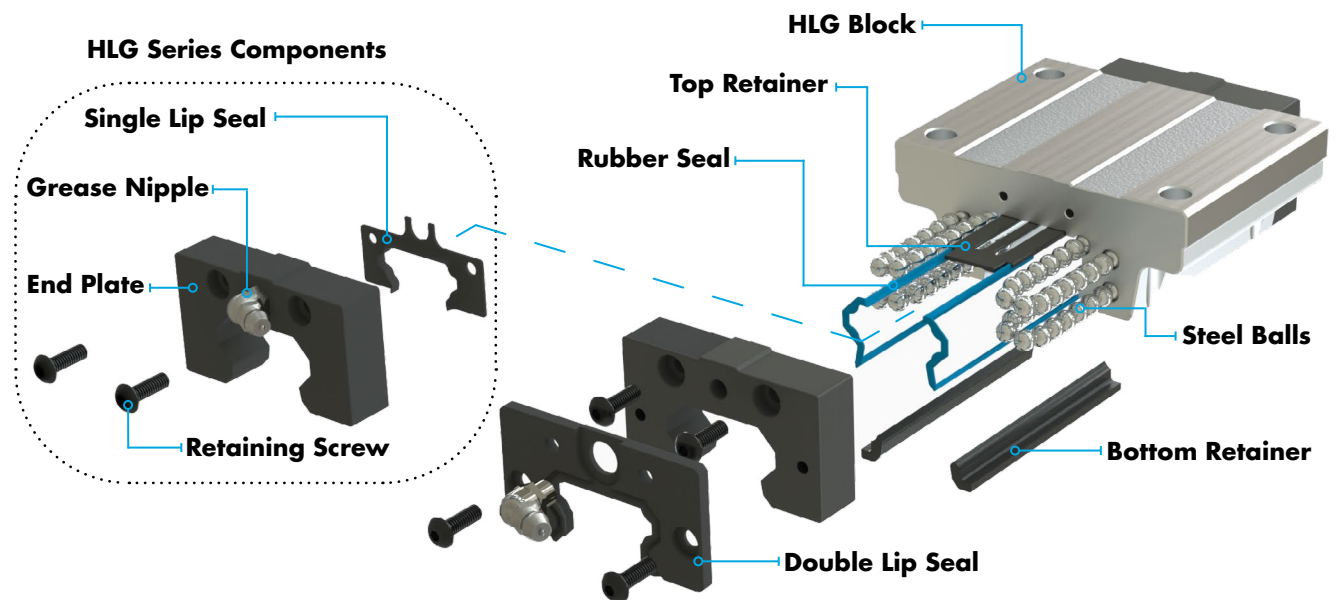

HLG's X-Arrangement Angular Contact Configuration

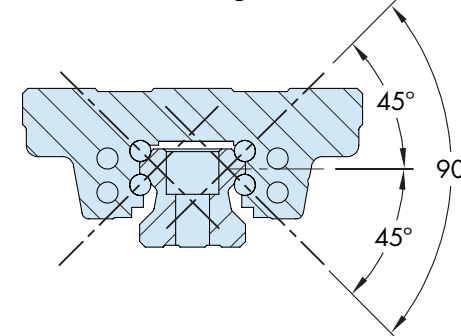

Spacer Chain Series Blocks

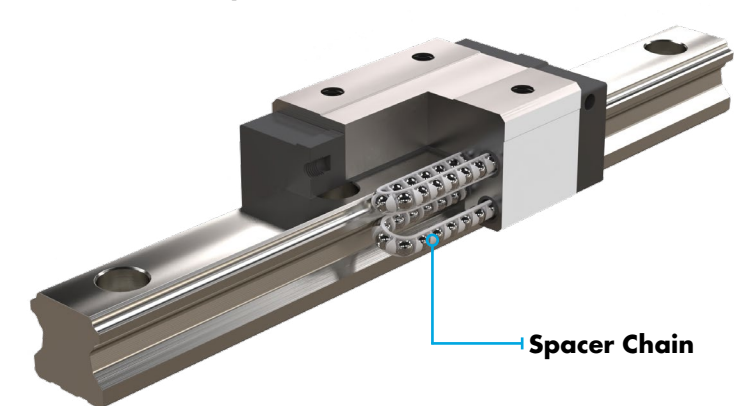

Features and Benefits

- Comprehensive range of precision and preload grades
- Short lead time available on most popular types
- Competitive prices
- Major dimensions and tolerances of HLG Standard Series comply with ISO 12090-1, enabling interchangeability
- Low deformation under external load provides rigidity
- Spacer Chain series for quiet operation and reduced maintenance
- X-arrangement accommodates some variation in height and parallelism in multiple guideway systems
- Environmental protection through integral seals
- Bleed lubrication facility option is available
- Brake option is available on all types

HepcoMotion's range of linear ball guides are designed to comply with international standards and come with a range of options to give the user choice in design and selection. Please contact Hepco for information on compatibility with other manufacturers rails or accessories.

Series	Part Number	Mounting Options	Key Features
HLG Standard & Spacer Chain Rectangular	HLG ... RN HLG ... RL HLG ... RNA HLG ... RLA HLG ... RNSA HLG ... RLSA		<ul style="list-style-type: none"> Interchangeable with ISO 12090-1 compliant systems Narrow design suitable for parallel mounting Highest load and moment load capacity Available in standard and long versions Available with Spacer Chain
HLG Standard & Spacer Chain Flanged	HLG ... FN HLG ... FL HLG ... FNA HLG ... FLA HLG ... FNSA HLG ... FLSA		<ul style="list-style-type: none"> Interchangeable with ISO 12090-1 compliant systems Additional mounting option Highest load and moment load capacity Available in standard and long versions Available with Spacer Chain
HLGS Compact & Spacer Chain Rectangular	HLGS ... RC HLGS ... RN HLGS ... RCA HLGS ... RNA HLGS ... RCSA HLGS ... RNSA		<ul style="list-style-type: none"> Compact design with optimised width and height Narrow design suitable for parallel mounting Light weight High load and moment load capacity Available in standard and short versions Available with Spacer Chain
HLGS Compact & Spacer Chain Flanged	HLGS ... FC HLGS ... FN HLGS ... FCA HLGS ... FNA HLGS ... FCSA HLGS ... FNSA		<ul style="list-style-type: none"> Compact design with optimised width and height Light weight Additional mounting option High load and moment load capacity Available in standard and short versions Available with Spacer Chain

Precision and Preload Options

Hepco offer a full range of sizes with precision and preload grades to meet your particular application requirements. To enable short delivery lead time, a select range across the most popular sizes (in Normal precision and 'Z0' Zero or 'Z1' Light preload) are held in stock. These are labelled 'Stock Range'. Normal Precision is ordered using the standard part number, High and Precision grades are ordered with a 'H' and 'P' suffix, respectively.

Precision Grades	
	Normal (Stock Range)
H	High
P	Precision
SP	Super Precision
UP	Ultra Precision

Preload Grades	
Z0	Zero Preload (Stock Range)
Z1	Light Preload (Stock Range)
Z2	Medium Preload

Rail Length Specification

HLG rail lengths are available in lengths up to 4000mm*. Standard rail lengths are offered in increments of one hole pitch, where the end dimensions 'C' and 'D' are equal and specified. The table below lists the hole pitches and standard end dimensions for the various rail sizes. Rails with custom 'C' and 'D' dimensions are available; simply specify the custom dimensions using the method as shown below.

Part No.	Pitch	C/D
HLG 15 ...	60	28
HLG 20 ...	60	28
HLG 25 ...	60	28
HLG 30 ...	80	38
HLG 35 ...	80	38
HLG 45 ...	105	51
HLG 55 ...	120	58

Ordering Example:

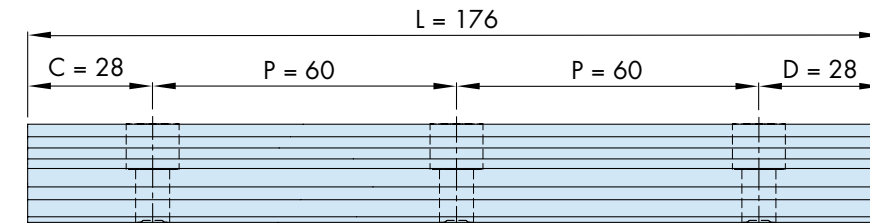

The above example shows a standard length HLG25 rail with two hole pitches (3 holes). The following method is used to calculate the length:

$$\text{Rail Length 'L'} = \text{End 'C'} + \text{End 'D'} + (\text{Number of pitches} \times \text{Rail Pitch 'P'})$$

$$176 = 28 + 28 + (2 \times 60)$$

Ordering details: **HLG25 L176 (C28) (D28)**

If 'C' and 'D' are left blank, the rail will be supplied with equal ends

Rail Mounting Options

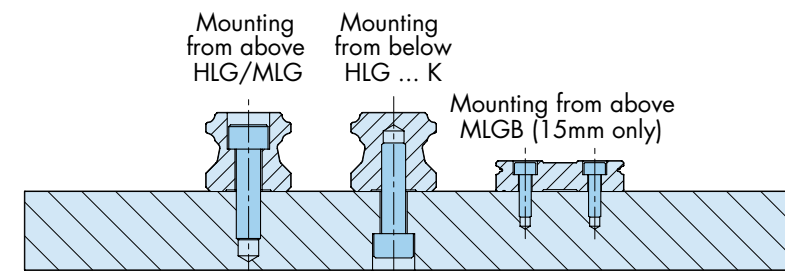

See [M28](#) for ordering details

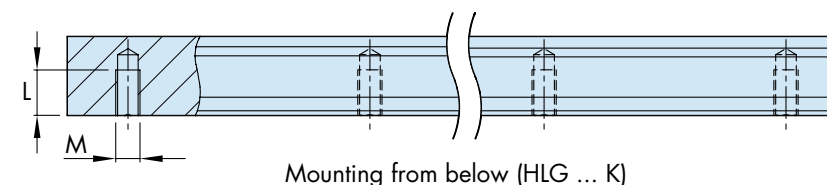

The table below shows the thread details and part numbers for HLG...K rail with the tapped hole mounting option.

Part No.	M x L
HLG 15 ... K	M5 x 8
HLG 20 ... K	M6 x 10
HLG 25 ... K	M6 x 12
HLG 30 ... K	M8 x 15
HLG 35 ... K	M8 x 17
HLG 45 ... K	M12 x 24
HLG 55 ... K	M14 x 24

Notes:

- Rail can be supplied at a maximum length of 4000mm with variable end dimensions. Contact Hepco's technical department for details.

HLG Standard Rectangular blocks offer higher load capacities compared to HLGS compact blocks. The high load capacity and narrow design are well suited for use in series, or in parallel installation in heavy applications. Long version blocks provide a higher moment capacity, suitable for individual heavy loads or for offset loading.

HLG...R series blocks are available in standard and long versions*¹ and comply with ISO 12090-1, enabling interchangeability with existing ISO-compatible systems.

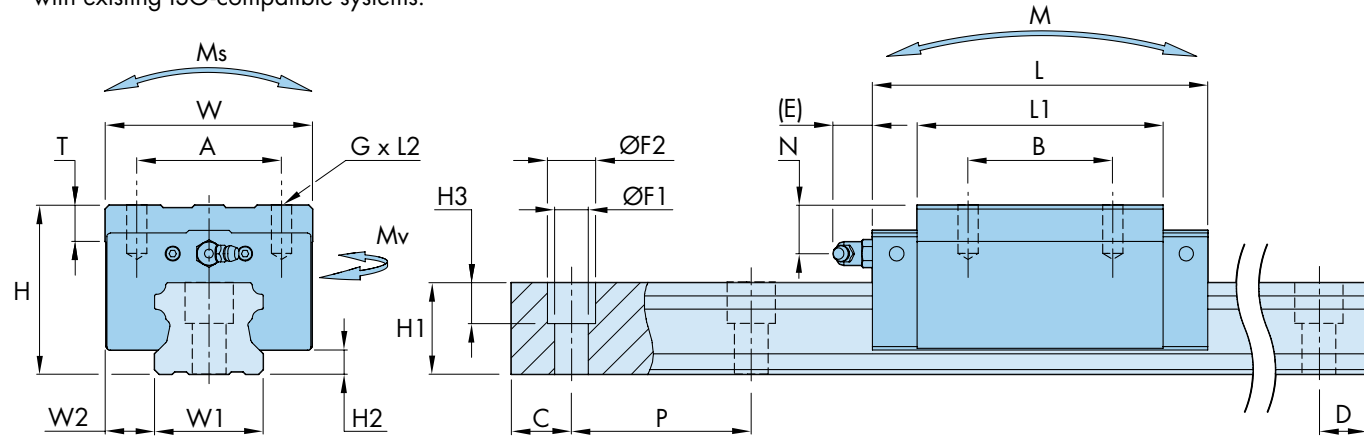

The "A" series block (e.g. HLG35RNA...) offers an improved sealing arrangement, and features an all-in-one lower guide to prevent ball loss. Due to the updated design, these differ from the non "A" series blocks in certain features and dimensions, which can be seen in the illustrations and table below:

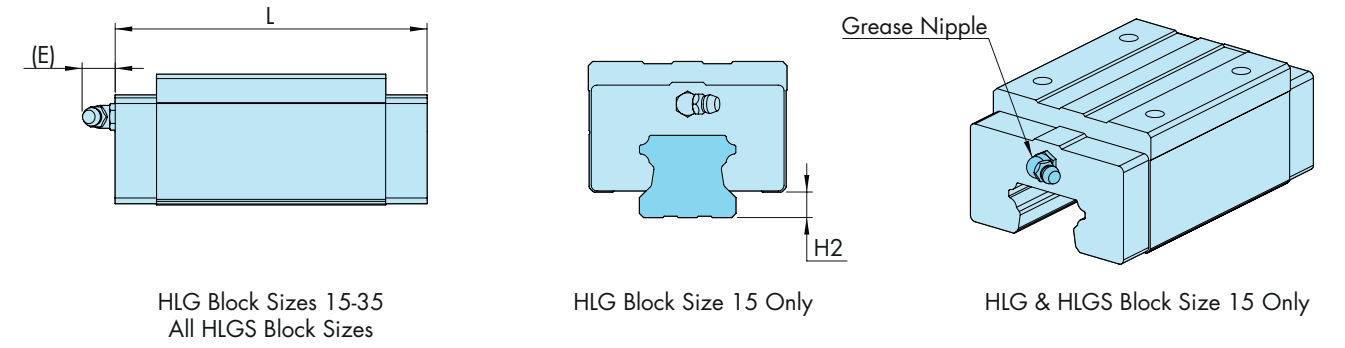

The illustrations above also relate to the changes to the Compact Rectangular Series blocks, which can be found on [8](#).

Part Number* ¹	Assembly Dimensions (mm)			Dimensions of HLG Block (mm)										Grease Nipple Thread	Dimensions of HLG Rail (mm)					Basic Load Rating (kN)		Static Moment Capacity (Nm)* ²			Weight		Part Number* ¹
	H	H2	W2	L	L1	W	A	B	G x L2	T	N	E	W1 ±0.05		H1	C/D	P	F1xF2xH3	C Dynamic	Co Static	M(max)	Mv(max)	M5(max)	HLG Block (kg)	HLG Rail (kg/m)		
HLG 15 RN ...	28	4.7	9.5	57	40.8	34	26	26	M4 x 5	6	10	6	M4	15	13	28	60	4.5x7.5x5.3	12.6	16.2	115	115	129	0.18	1.3	HLG 15 RN ...	
HLG 15 RL ...		4.5		65.3	49.1														14.3	19.3	165	165	154			0.23	HLG 15 RL ...
HLG 15 RNA...		4.5		56.5	40.8														12.6	16.2	115	115	129			0.18	HLG 15 RNA...
HLG 15 RLA ...		4.5		64.8	49.1														14.3	19.3	165	165	154			0.23	HLG 15 RLA ...
HLG 20 RN ...	30	6	12	72.7	53.1	44	32	36	M5 x 6	8	7.5	12	M6x0.75	20	16.5	28	60	6x9.5x8.5	18.3	23.9	221	221	251	0.31	2.2	HLG 20 RN ...	
HLG 20 RL ...				88.6	69			21.8											30.7	370	370	322	0.41			HLG 20 RL ...	
HLG 20 RNA...				73.2	53.1			18.3											23.9	221	221	251	0.31			HLG 20 RNA...	
HLG 20 RLA ...				89.1	69			21.8											30.7	370	370	322	0.41			HLG 20 RLA ...	
HLG 25 RN ...	40	7	12.5	83	58.3	48	35	35	M6 x 8	8	13	12	M6x0.75	23	20	28	60	7x11x9	27.0	33.1	337	337	398	0.53	3.0	HLG 25 RN ...	
HLG 25 RL ...				102.9	78.2			32.8											43.6	596	596	525	0.71			HLG 25 RL ...	
HLG 25 RNA...				83.2	58.3			27.0											33.1	337	337	398	0.53			HLG 25 RNA...	
HLG 25 RLA ...				103.1	78.2			32.8											43.6	596	596	525	0.71			HLG 25 RLA ...	
HLG 30 RN ...	45	7.5	16	97.8	70.8	60	40	40	M8 x 10	8	10.3	12	M6x0.75	28	26	38	80	9x14x12	50.4	57.1	711	711	828	0.9	4.85	HLG 30 RN ...	
HLG 30 RL ...				120	93			60.3											73.6	1203	1203	1067	1.1			HLG 30 RL ...	
HLG 30 RNA...				99.3	70.8			50.4											57.1	711	711	828	0.9			HLG 30 RNA...	
HLG 30 RLA ...				121.5	93			60.3											73.6	1203	1203	1067	1.1			HLG 30 RLA ...	
HLG 35 RN ...	55	9	18	110	80.8	70	50	50	M8 x 12	10	15	12	M6x0.75	34	29	38	80	9x14x12	67.0	74.6	1062	1062	1298	1.5	6.58	HLG 35 RN ...	
HLG 35 RL ...				135.4	106.2			80.2											96.2	1797	1797	1674	2.01			HLG 35 RL ...	
HLG 35 RNA...				111.8	80.8			67.0											74.6	1062	1062	1298	1.5			HLG 35 RNA...	
HLG 35 RLA ...				137.2	106.2			80.2											96.2	1797	1797	1674	2.01			HLG 35 RLA ...	
HLG 45 RN ...	70	10	20.5	139	101.9	86	60	60	M10 x 17	15	20	16	PT1/8	45	38	51	105	14x20x17	108.5	116.4	2860	2860	2275	2.89	11.03	HLG 45 RN ...	
HLG 45 RL ...				170.8	133.7			129.7											150.1	4533	4533	2935	3.74			HLG 45 RL ...	
HLG 55 RN ...	80	13	23.5	163	117.5	100	75	75	M12 x 18	18	21	16	PT1/8	53	44	58	120	16x23x20	155.9	161.5	4654	4654	3779	4.28	15.26	HLG 55 RN ...	
HLG 55 RL ...				201.1	155.6			187.5											210.1	7468	7468	4916	5.59			HLG 55 RL ...	

Notes:

- See [28](#) for part number configuration and ordering details.
- For more details on moment capacity and calculating system life, please see [25](#).

HLG Standard Flanged blocks can be used where mounting methods are limited and through fixing from below is necessary. The blocks offer higher load and moment capacity when compared to HLGS compact flanged blocks. HLG...F series blocks are available in standard and long versions*¹ and comply with ISO 12090-1, enabling interchangeability with existing ISO-compatible systems.

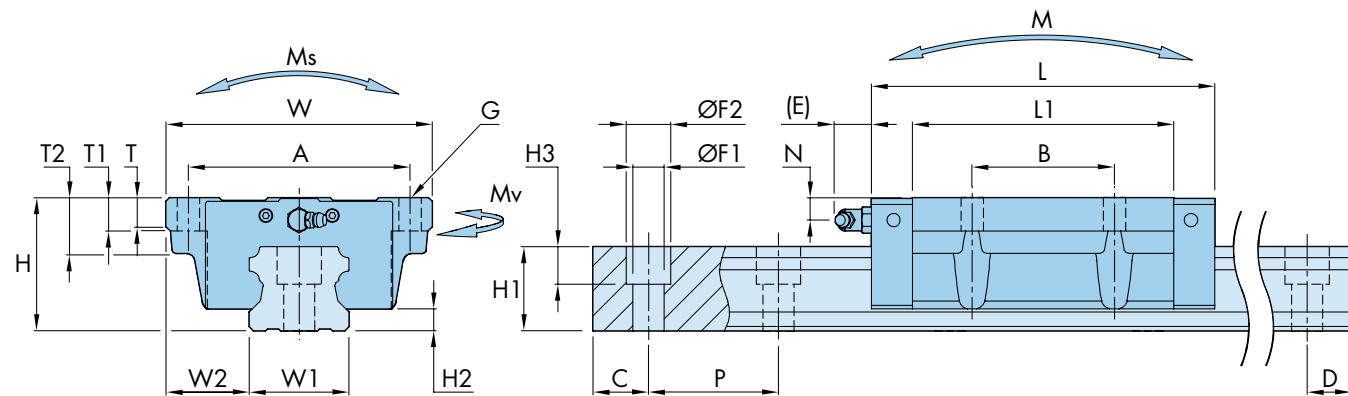

The "A" series block (e.g. HLG35FNA...) offers an improved sealing arrangement, and features an all-in-one lower guide to prevent ball loss. Due to the updated design, these differ from the non "A" series blocks in certain features and dimensions, which can be seen in the illustrations and table below:

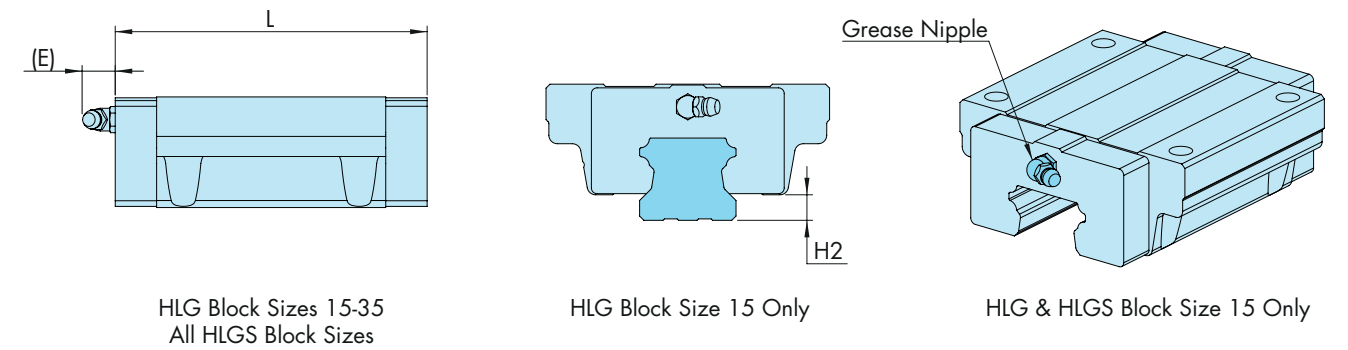

The illustrations above also relate to the changes to the Compact Flanged Series blocks, which can be found on [p. 9](#).

Part Number* ¹	Assembly Dimensions (mm)			Dimensions of HLG Block (mm)											Grease Nipple Thread	Dimensions of HLG Rail (mm)					Basic Load Rating (kN)		Static Moment Capacity (Nm) ^{*2}			Weight		Part Number* ¹
	H	H2	W2	L	L1	W	A	B	G	T	T1	T2	N	E		W1 ±0.05	H1	C/D	P	F1xF2xH3	C Dynamic	Co Static	M(max)	Mv(max)	Ms(max)	HLG Block (kg)	HLG Rail (kg/m)	
HLG 15 FN ...	24	4.7	16	57	40.8	47	38	30	M5	7	11	-	6	6	M4	15	13	28	60	4.5x7.5x5.3	12.6	16.2	115	115	129	0.19	1.3	HLG 15 FN ...
HLG 15 FL ...		14.3		19.3	165																165	154	HLG 15 FL ...					
HLG 15 FNA...		12.6		16.2	115																115	129	HLG 15 FNA ...					
HLG 15 FLA ...		14.3		19.3	165																165	154	HLG 15 FLA ...					
HLG 20 FN ...	30	6	21.5	72.7	53.1	63	53	40	M6	9.2	10	-	7.5	12	M6x0.75	20	16.5	28	60	6x9.5x8.5	18.3	23.9	221	221	251	0.41	2.2	HLG 20 FN ...
HLG 20 FL ...				21.8	30.7									370							370	322	HLG 20 FL ...					
HLG 20 FNA...				18.3	23.9									221							221	251	HLG 20 FNA ...					
HLG 20 FLA ...				21.8	30.7									370							370	322	HLG 20 FLA ...					
HLG 25 FN ...	36	7	23.5	83	58.3	70	57	45	M8	11.5	16	-	9	12	M6x0.75	23	20	28	60	7x11x9	27.0	33.1	337	337	398	0.61	3.0	HLG 25 FN ...
HLG 25 FL ...				32.8	43.6									596							596	525	HLG 25 FL ...					
HLG 25 FNA...				27.0	33.1									337							337	398	HLG 25 FNA ...					
HLG 25 FLA ...				32.8	43.6									596							596	525	HLG 25 FLA ...					
HLG 30 FN ...	42	7.5	31	97.8	70.8	90	72	52	M10	9.5	18	-	7.3	12	M6x0.75	28	26	38	80	9x14x12	50.4	57.1	711	711	828	1.1	4.85	HLG 30 FN ...
HLG 30 FL ...				60.3	73.6									1203							1203	1067	HLG 30 FL ...					
HLG 30 FNA...				50.4	57.1									711							711	828	HLG 30 FNA ...					
HLG 30 FLA ...				60.3	73.6									1203							1203	1067	HLG 30 FLA ...					
HLG 35 FN ...	48	9	33	110	80.8	100	82	62	M10	12.5	21	-	8	12	M6x0.75	34	29	38	80	9x14x12	67.0	74.6	1062	1062	1298	1.6	6.58	HLG 35 FN ...
HLG 35 FL ...				80.2	96.2									1797							1797	1674	HLG 35 FL ...					
HLG 35 FNA...				67.0	74.6									1062							1062	1298	HLG 35 FNA ...					
HLG 35 FLA ...				80.2	96.2									1797							1797	1674	HLG 35 FLA ...					
HLG 45 FN ...	60	10	37.5	139	101.9	120	100	80	M12	13	15	25	10	16	PT1/8	45	38	51	105	14x20x17	108.5	116.4	2860	2860	2275	2.83	11.03	HLG 45 FN ...
HLG 45 FL ...				129.7	150.1																4533	4533	2935	HLG 45 FL ...				
HLG 55 FN ...	70	13	43.5	163	117.5	140	116	95	M14	19	17	29	11	16	PT1/8	53	44	58	120	16x23x20	155.9	161.5	4654	4654	3779	4.36	15.26	HLG 55 FN ...
HLG 55 FL ...				187.5	210.1																7468	7468	4916	HLG 55 FL ...				

Notes:

- See [p. 28](#) for part number configuration and ordering details.
- For more details on moment capacity and calculating system life, please see [p. 25](#).

HLGS Compact Rectangular type blocks provide an optimised width, height and length.

HLGS...RN series blocks are a more compact version of the standard HLG...RN series block, whilst offering similar moment and load capacities.

HLGS...RC series blocks are the most compact block in the HLG range and well suited for mounting in series, or parallel, where space is limited. HLGS blocks can also benefit lightweight applications with a reduced weight compared to standard HLG blocks*1.

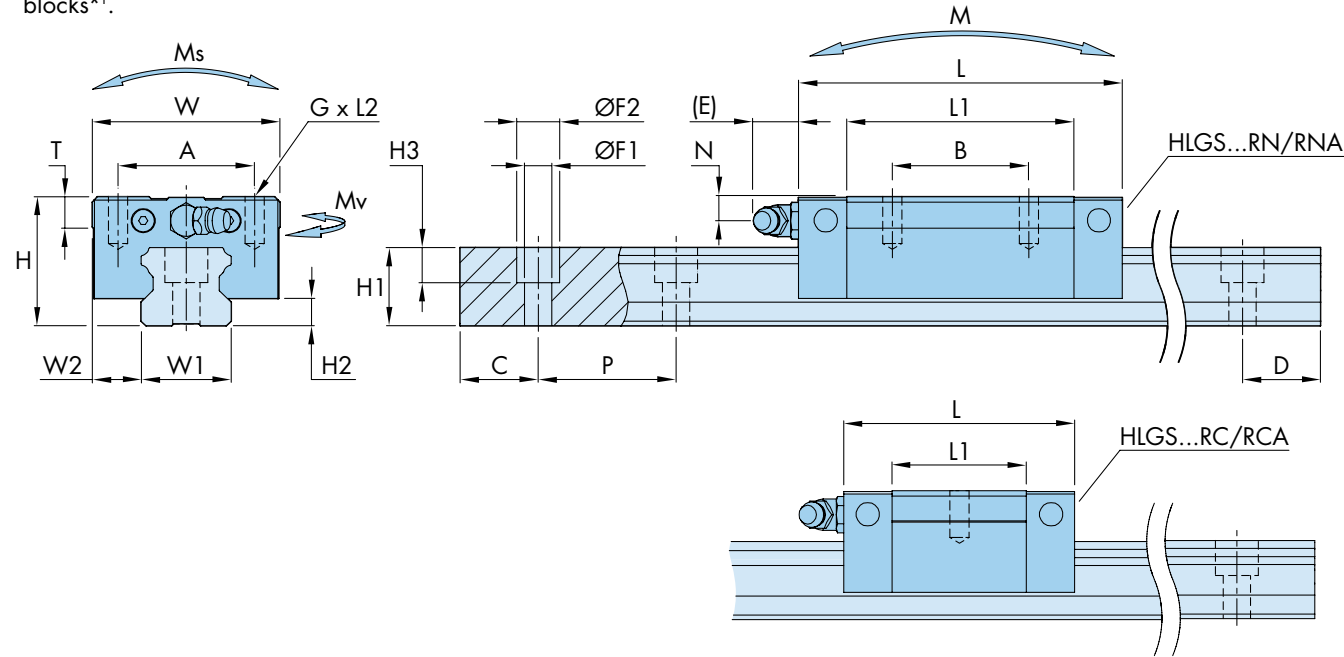

Part Number*1	Assembly Dimensions (mm)			Dimensions of HLGS Block (mm)									Grease Nipple Thread
	H	H2	W2	L	L1	W	A	B	G x L2	T	N	E	
HLGS 15 RC ...	24	4.5	9.5	40.2	24	34	26	-	M4 x 6	6	6	6	M4
HLGS 15 RN ...				56.9	40.8			26					
HLGS 15 RCA ...				39.8	24			-					
HLGS 15 RNA...				56.5	40.8			26					
HLGS 20 RC ...	28	6	11	47.2	27.6	42	32	-	M5 x 7	7.5	5.5	12	M6x0.75
HLGS 20 RN ...				66.3	46.7			32					
HLGS 20 RCA ...				47.8	27.6			-					
HLGS 20 RNA...				66.8	46.7			32					
HLGS 25 RC ...	33	7	12.5	59.1	34.4	48	35	-	M6 x 8	8	6	12	M6x0.75
HLGS 25 RN ...				83	58.2			35					
HLGS 25 RCA ...				59.4	34.4			-					
HLGS 25 RNA...				83.2	58.2			35					

Part Number*1	Dimensions of HLG Rail (mm)					Basic Load Rating (kN)		Static Moment Capacity (Nm)*2			Weight	
	W1 ±0.05	H1	C/D	P	F1xF2xH3	C	Co	M(max)	MV(max)	MS(max)	HLGS Block (kg)	HLG Rail (kg/m)
HLGS 15 RC ...	15	13	28	60	4.5x7.5x5.3	9.0	10.0	42	42	79	0.10	1.3
HLGS 15 RN ...						12.6	16.2	115	115	129	0.16	
HLGS 15 RCA ...						9.0	10.0	42	42	79	0.10	
HLGS 15 RNA...						12.6	16.2	115	115	129	0.16	
HLGS 20 RC ...	20	16.5	28	60	6x9.5x8.5	12.0	13.1	63	63	137	0.15	2.2
HLGS 20 RN ...						16.8	21.2	173	173	223	0.25	
HLGS 20 RCA ...						12.0	13.1	63	63	137	0.15	
HLGS 20 RNA...						16.8	21.2	173	173	223	0.25	
HLGS 25 RC ...	23	20	28	60	7x11x9	19.2	20.4	123	123	246	0.25	3.0
HLGS 25 RN ...						27.0	33.1	337	337	398	0.41	
HLGS 25 RCA ...						19.2	20.4	123	123	246	0.25	
HLGS 25 RNA...						27.0	33.1	337	337	398	0.41	

Notes:

- See [28](#) for part number configuration and ordering details.
- For more details on moment capacity and calculating system life, please see [25](#).
- Please see [5](#) for information on the "A" (e.g. HLGS20RCA...) series blocks.

HLGS Compact Flanged type blocks provide an optimised width, height and length.

HLGS...FN series blocks are a more compact version of the standard HLG...FN series block, whilst offering similar moment and load capacities.

HLGS...FC series blocks are a shorter version of the HLG...FN flanged block and well suited for mounting in series, or parallel, where space is limited and through fixing is necessary. HLGS blocks can also benefit lightweight applications with a reduced weight compared to standard HLG blocks*1.

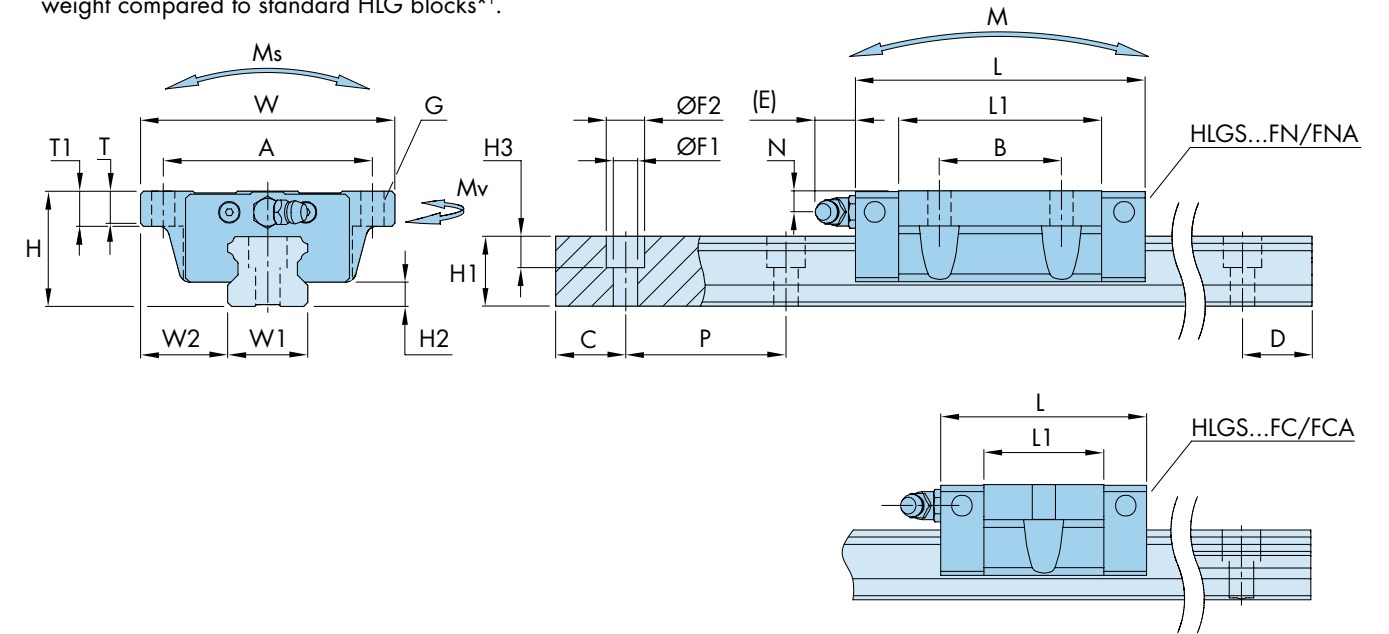

Part Number*1	Assembly Dimensions (mm)			Dimensions of HLGS Block (mm)									Grease Nipple Thread	
	H	H2	W2	L	L1	W	A	B	G	T	T1	N		E
HLGS 15 FC ...	24	4.5	18.5	40.2	24	52	41	-	M5	6	7	6	6	M4
HLGS 15 FN ...				56.9	40.8			26						
HLGS 15 FCA ...				39.8	24			-						
HLGS 15 FNA...				56.5	40.8			26						
HLGS 20 FC ...	28	6	19.5	47.8	27.6	59	49	-	M6	8	9	5.5	12	M6x0.75
HLGS 20 FN ...				66.8	46.7			32						
HLGS 20 FCA ...				47.8	27.6			-						
HLGS 20 FNA...				66.8	46.7			32						
HLGS 25 FC ...	33	7	25	59.4	34.4	73	60	-	M8	9	10	6	12	M6x0.75
HLGS 25 FN ...				83.2	58.2			35						
HLGS 25 FCA ...				59.4	34.4			-						
HLGS 25 FNA...				83.2	58.2			35						

Part Number*1	Dimensions of HLG Rail (mm)					Basic Load Rating (kN)		Static Moment Capacity (Nm)*2			Weight	
	W1 ±0.05	H1	C/D	P	F1xF2xH3	C	Co	M(max)	MV(max)	MS(max)	HLGS Block (kg)	HLG Rail (kg/m)
HLGS 15 FC ...	15	13	28	60	4.5x7.5x5.3	9.0	10.0	42	42	79	0.13	1.3
HLGS 15 FN ...						12.6	16.2	115	115	129	0.20	
HLGS 15 FCA ...						9.0	10.0	42	42	79	0.13	
HLGS 15 FNA...						12.6	16.2	115	115	129	0.20	
HLGS 20 FC ...	20	16.5	28	60	6x9.5x8.5	12.0	13.1	63	63	137	0.19	2.2
HLGS 20 FN ...						16.8	21.2	173	173	223	0.30	
HLGS 20 FCA ...						12.0	13.1	63	63	137	0.19	
HLGS 20 FNA...						16.8	21.2	173	173	223	0.30	
HLGS 25 FC ...	23	20	28	60	7x11x9	19.2	20.4	123	123	246	0.32	3.0
HLGS 25 FN ...						27.0	33.1	337	337	398	0.53	
HLGS 25 FCA ...						19.2	20.4	123	123	246	0.32	
HLGS 25 FNA...						27.0	33.1	337	337	398	0.53	

Notes:

- See [28](#) for part number configuration and ordering details.
- For more details on moment capacity and calculating system life, please see [25](#).
- Please see [7](#) for information on the "A" (e.g. HLGS20FCA...) series blocks.

Like the HLG...R series blocks, the new HLG Spacer Chain Rectangular Series blocks have the same features and benefits, but utilise a spacer chain between the balls to prevent them from colliding with each other when circulating. This allows for a more stable circulation of the balls, which reduces the loss of oil film when the system is in motion. With no collision, noise is also heavily reduced, especially at high speeds.

HLG...R Spacer Chain series blocks are available in standard and long versions and comply with ISO 12090-1, enabling interchangeability with existing ISO-compatible systems.

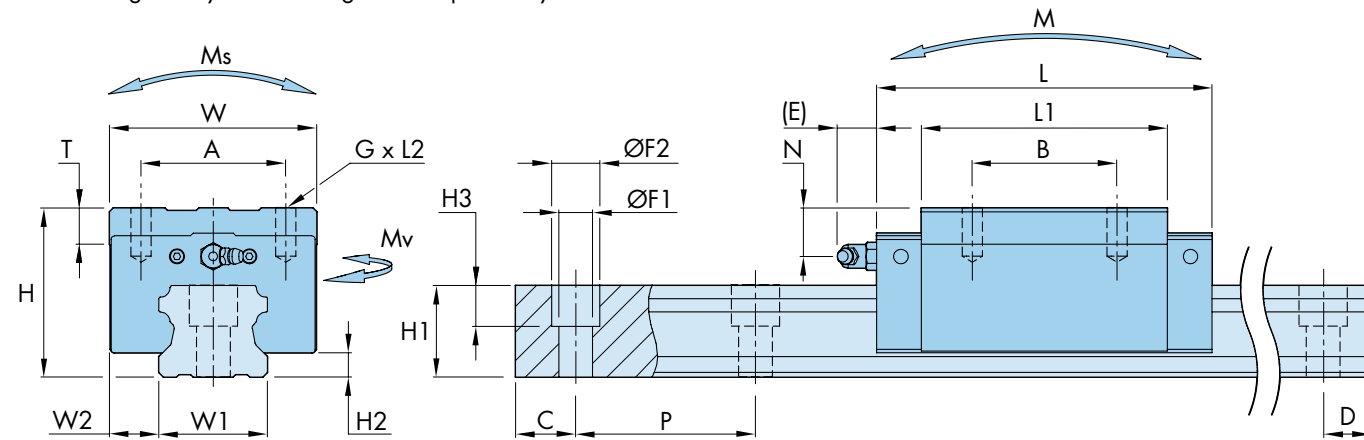

Part Number*1	Assembly Dimensions (mm)			Dimensions of HLG Block (mm)									Grease Nipple Thread
	H	H2	W2	L	L1	W	A	B	G x L2	T	N	E	
HLG 15 RNSA...	28	4.5	9.5	56.5	40.8	34	26	26	M4 x 5	6	10	4.7	M5
HLG 15 RLSA ...				64.8	49.1								
HLG 20 RNSA...	30	6	12	73.2	53.1	44	32	36	M5 x 6	8	7.5	10.7	M6x0.75
HLG 20 RLSA ...				89.1	69			50					
HLG 25 RNSA ...	40	7	12.5	83.2	58.2	48	35	35	M6 x 8	8	13	10.2	M6x0.75
HLG 25 RLSA ...				103.1	78.2			50					
HLG 30 RNSA...	45	7.5	16	99.3	70.8	60	40	40	M8 x 10	8	10.3	9.8	M6x0.75
HLG 30 RLSA ...				121.5	93			60					
HLG 35 RNSA...	55	9	18	111.8	80.8	70	50	50	M8 x 12	10	15	9.7	M6x0.75
HLG 35 RLSA ...				137.2	106.2			72					

Part Number*1	Dimensions of HLG Rail (mm)					Basic Load Rating (kN)		Static Moment Capacity (Nm)*2			Weight	
	W1 ±0.05	H1	C/D	P	F1xF2xH3	C Dynamic	Co Static	M(max)	MV(max)	MS(max)	HLGC Block (kg)	HLG Rail (kg/m)
HLG 15 RNSA...	15	13	28	60	4.5x7.5x5.3	12.1	16.2	115	115	129	0.18	1.3
HLG 15 RLSA ...						13.7	19.3	165	165	154	0.23	
HLG 20 RNSA...	20	16.5	28	60	6x9.5x8.5	17.6	23.9	221	221	251	0.31	2.2
HLG 20 RLSA ...						21.1	30.7	370	370	322	0.41	
HLG 25 RNSA...	23	20	28	60	7x11x9	25.8	33.1	337	337	398	0.53	3.0
HLG 25 RLSA ...						31.7	43.6	596	596	525	0.71	
HLG 30 RNSA...	28	26	38	80	9x14x12	48	57.1	711	711	828	0.9	4.85
HLG 30 RLSA ...						58	73.6	1203	1203	1067	1.1	
HLG 35 RNSA...	34	29	38	80	9x14x12	63.7	74.6	1062	1062	1298	1.5	6.58
HLG 35 RLSA ...						77.1	96.2	1797	1797	1674	2.01	

Notes:

- See [28](#) for part number configuration and ordering details.
- For more details on moment capacity and calculating system life, please see [25](#).
- Please see [5](#) for information on the "A" (e.g. HLG20RNSA...) series blocks.

Like the HLG...F series blocks, the new HLG Spacer Chain Flanged Series blocks have the same features and benefits, but utilise a spacer between the balls to prevent them from colliding with each other when circulating. This allows for a more stable circulation of the balls, which reduces the loss of oil film when the system is in motion. With no collisions, noise is also heavily reduced, especially at high speeds.

HLG...F Spacer Chain series blocks are available in standard and long versions and comply with ISO 12090-1, enabling interchangeability with existing ISO-compatible systems.

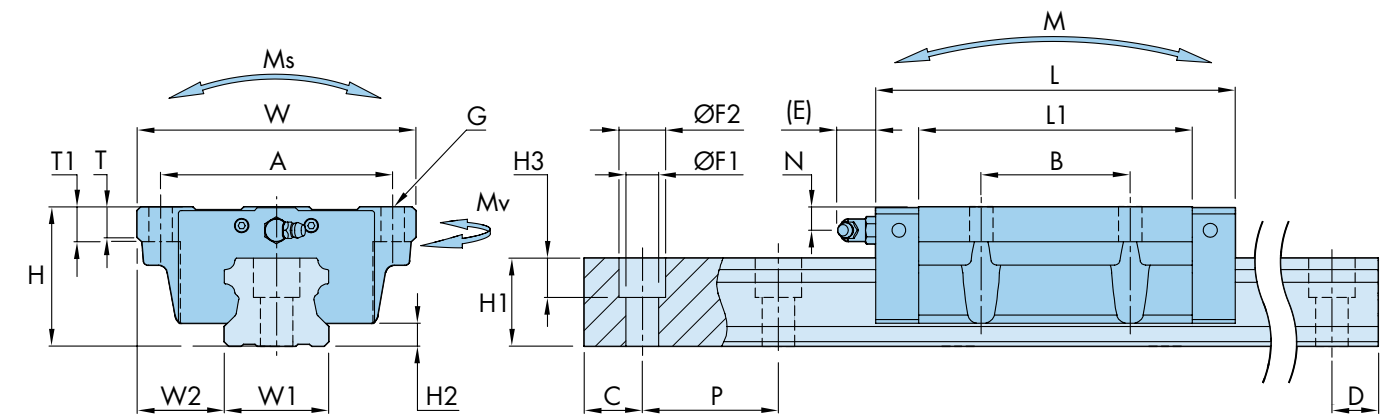

Part Number*1	Assembly Dimensions (mm)			Dimensions of HLG Block (mm)									Grease Nipple Thread	
	H	H2	W2	L	L1	W	A	B	G	T	T1	N		E
HLG 15 FNSA ...	24	4.5	16	56.5	40.8	47	38	30	M5	7	11	6.0	4.7	M5
HLG 15 FLSA ...				64.8	49.1									
HLG 20 FNSA ...	30	6	21.5	73.2	53.1	63	53	40	M6	9.2	10	7.5	10.7	M6x0.75
HLG 20 FLSA ...				89.1	69.0									
HLG 25 FNSA ...	36	7	23.5	83.2	58.3	70	57	45	M8	11.5	16	9.0	10.2	M6x0.75
HLG 25 FLSA ...				103.1	78.2									
HLG 30 FNSA ...	42	7.5	31	99.3	70.8	90	72	52	M10	9.5	18	7.3	9.8	M6x0.75
HLG 30 FLSA ...				121.5	93.0									
HLG 35 FNSA ...	48	9	33	111.8	80.8	100	82	62	M10	12.5	21	8.0	9.7	M6x0.75
HLG 35 FLSA ...				137.2	106.2									

Part Number*1	Dimensions of HLG Rail (mm)					Basic Load Rating (kN)		Static Moment Capacity (Nm)*2			Weight	
	W1 ±0.05	H1	C/D	P	F1xF2xH3	C Dynamic	Co Static	M(max)	MV(max)	MS(max)	HLGC Block (kg)	HLG Rail (kg/m)
HLG 15 FNSA ...	15	13	28	60	4.5x7.5x5.3	12.1	16.2	115	115	129	0.19	1.3
HLG 15 FLSA ...						13.7	19.3	165	165	154	0.24	
HLG 20 FNSA ...	20	16.5	28	60	6x9.5x8.5	17.6	23.9	221	221	251	0.41	2.2
HLG 20 FLSA ...						21.1	30.7	370	370	322	0.54	
HLG 25 FNSA ...	23	20	28	60	7x11x9	25.8	33.1	337	337	398	0.61	3.0
HLG 25 FLSA ...						31.7	43.6	596	596	525	0.82	
HLG 30 FNSA ...	28	26	38	80	9x14x12	48	57.1	711	711	828	1.1	4.85
HLG 30 FLSA ...						58	73.6	1203	1203	1067	1.3	
HLG 35 FNSA ...	34	29	38	80	9x14x12	63.7	74.6	1062	1062	1298	1.6	6.58
HLG 35 FLSA ...						77.1	96.2	1797	1797	1674	2.01	

Notes:

- See [28](#) for part number configuration and ordering details.
- For more details on moment capacity and calculating system life, please see [25](#).
- Please see [5](#) for information on the "A" (e.g. HLG20FNSA...) series blocks.

Like the HLGS...R series blocks, the new HLGS Compact Spacer Chain Rectangular Series blocks have the same features and benefits, but utilise a spacer between the balls to prevent them from colliding with each other when circulating. This allows for a more stable circulation of the balls, which reduces the loss of oil film when the system is in motion. With no collisions, noise is also heavily reduced, especially at high speeds.

HLGS...R Spacer Chain series blocks are available in standard and short versions and comply with ISO 12090-1, enabling interchangeability with existing ISO-compatible systems.

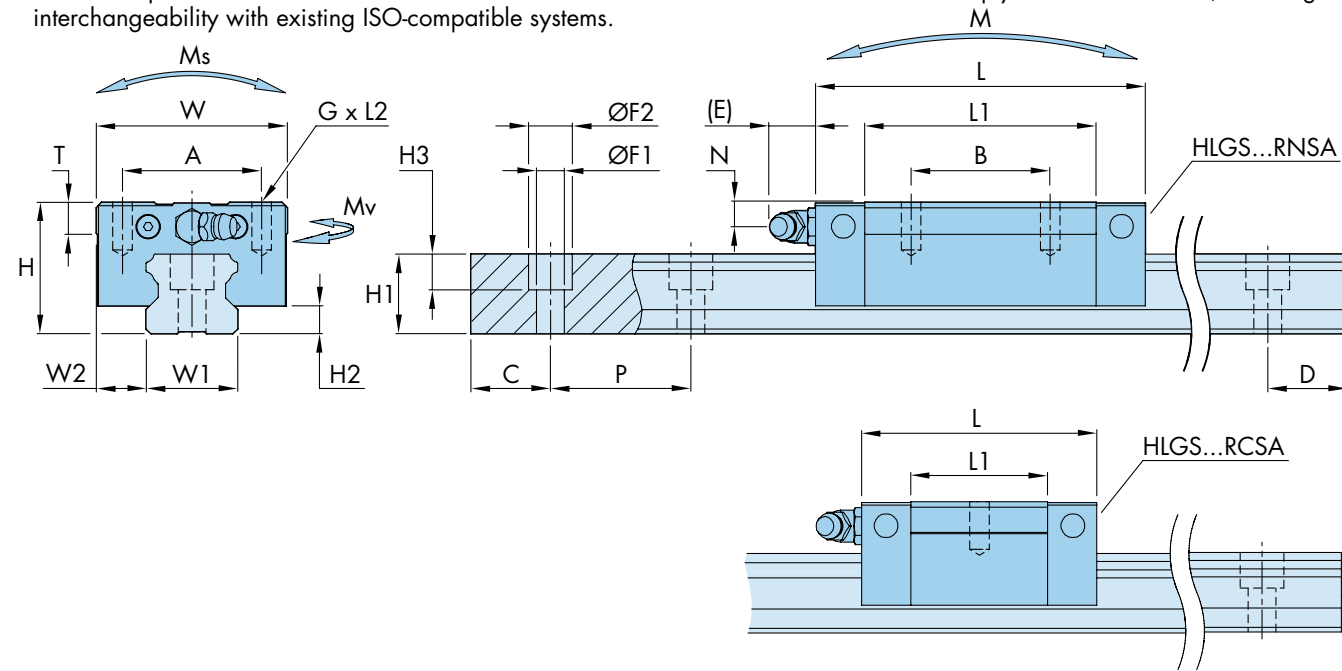

Part Number*1	Assembly Dimensions (mm)			Dimensions of HLGS Block (mm)										Grease Nipple Thread
	H	H2	W2	L	L1	W	A	B	G x L2	T	N	E		
HLGS 15 RCSA ...	24	4.5	9.5	39.8	24	34	26	-	M4 x 6	6	6	4.7	M5	
HLGS 15 RNSA ...				56.5	40.8			26						
HLGS 20 RCSA ...	28	6	11	47.8	27.6	42	32	-	M5 x 7	7.5	5.5	10.7	M6x0.75	
HLGS 20 RNSA ...				66.8	46.7			32						
HLGS 25 RCSA ...	33	7	12.5	59.4	34.4	48	35	-	M6 x 8	8	6	10.2	M6x0.75	
HLGS 25 RNSA ...				83.2	58.2			35						

Part Number*1	Dimensions of HLG Rail (mm)					Basic Load Rating (kN)		Static Moment Capacity (Nm)*2			Weight	
	W1 ±0.05	H1	C/D	P	F1xF2xH3	C Dynamic	Co Static	M(max)	MV(max)	MS(max)	HLGS Block (kg)	HLG Rail (kg/m)
HLGS 15 RCSA ...	15	13	28	60	4.5x7.5x5.3	8.3	10.0	42	42	79	0.10	1.3
HLGS 15 RNSA ...						12.1	16.2	115	115	129	0.16	
HLGS 20 RCSA ...	20	16.5	28	60	6x9.5x8.5	11.1	13.1	63	63	137	0.15	2.2
HLGS 20 RNSA ...						16.1	21.2	173	173	223	0.25	
HLGS 25 RCSA ...	23	20	28	60	7x11x9	17.9	20.4	123	123	246	0.25	3.0
HLGS 25 RNSA ...						25.8	33.1	337	337	398	0.41	

Notes:

- See 28 for part number configuration and ordering details.
- For more details on moment capacity and calculating system life, please see 25.
- Please see 5 for information on the "A" series (e.g. HLGS20RCSA...) series blocks.

Like the HLGS...F series blocks, the new HLGS Compact Spacer Chain Flanged Series blocks have the same features and benefits, but utilise a spacer between the balls to prevent them from colliding with each other when circulating. This allows for a more stable circulation of the balls, which reduces the loss of oil film when the system is in motion. With no collisions, noise is also heavily reduced, especially at high speeds.

HLGS...F Spacer Chain series blocks are available in standard and short versions and comply with ISO 12090-1, enabling interchangeability with existing ISO-compatible systems.

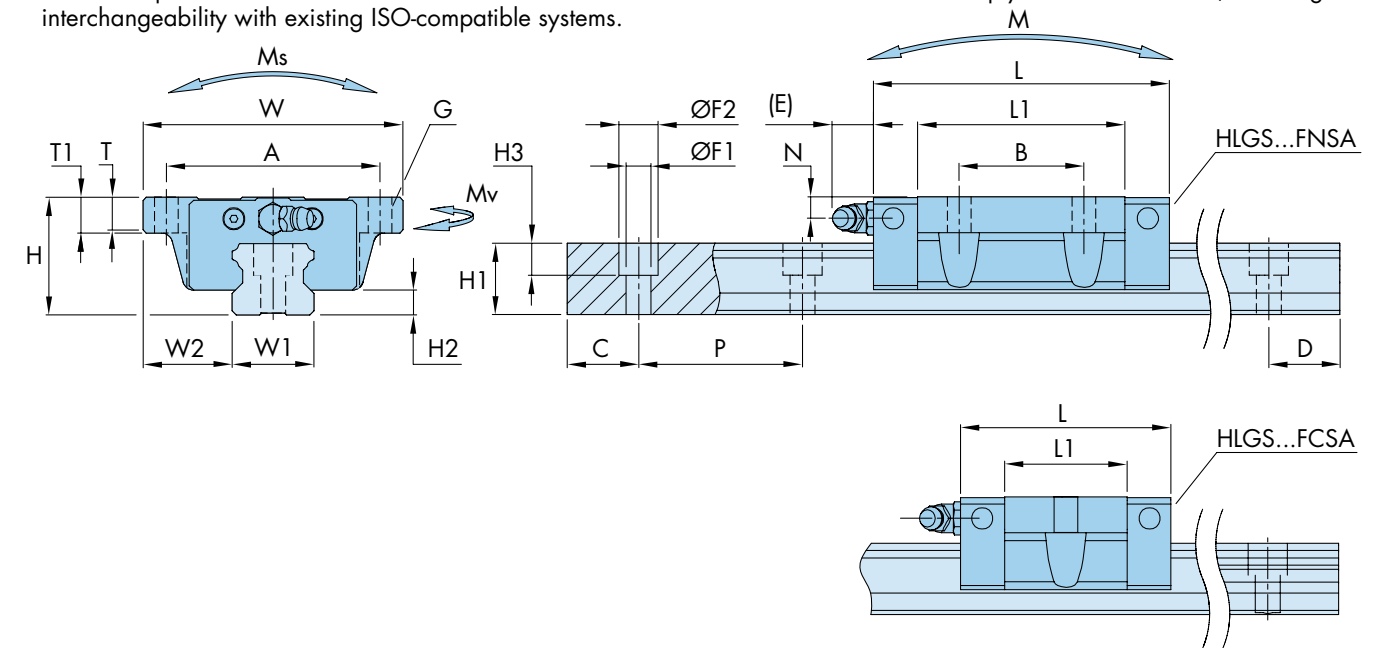

Part Number*1	Assembly Dimensions (mm)			Dimensions of HLGS Block (mm)										Grease Nipple Thread
	H	H2	W2	L	L1	W	A	B	G	T	T1	N	E	
HLGS 15 FCSA ...	24	4.5	18.5	39.8	24	52	41	-	M5	6	7	6	4.7	M5
HLGS 15 FNSA ...				56.5	40.8			26						
HLGS 20 FCSA ...	28	6	19.5	47.8	27.6	59	49	-	M6	8	9	5.5	10.7	M6x0.75
HLGS 20 FNSA ...				66.8	46.7			32						
HLGS 25 FCSA ...	33	7	25	59.4	34.4	73	60	-	M8	9	10	6	10.2	M6x0.75
HLGS 25 FNSA ...				83.2	58.2			35						

Part Number*1	Dimensions of HLG Rail (mm)					Basic Load Rating (kN)		Static Moment Capacity (Nm)*2			Weight	
	W1 ±0.05	H1	C/D	P	F1xF2xH3	C Dynamic	Co Static	M(max)	MV(max)	MS(max)	HLGS Block (kg)	HLG Rail (kg/m)
HLGS 15 FCSA ...	15	13	28	60	4.5x7.5x5.3	8.3	10.0	42	42	79	0.13	1.3
HLGS 15 FNSA ...						12.1	16.2	115	115	129	0.20	
HLGS 20 FCSA ...	20	16.5	28	60	6x9.5x8.5	11.1	13.1	63	63	137	0.19	2.2
HLGS 20 FNSA ...						16.1	21.2	173	173	223	0.30	
HLGS 25 FCSA ...	23	20	28	60	7x11x9	17.9	20.4	123	123	246	0.32	3.0
HLGS 25 FNSA ...						25.8	33.1	337	337	398	0.53	

Notes:

- See 28 for part number configuration and ordering details.
- For more details on moment capacity and calculating system life, please see 25.
- Please see 7 for information on the "A" (e.g. HLGS20FCSA...) series blocks.

Introducing HepcoMotion MLG Linear Ball Guides

HepcoMotion's miniature guides have a four point contact ball recirculating system with 45° loading angles. There are two recirculating paths per carriage providing smooth movement over the complete stroke length.

These precision units will provide exceptional load capacity in a very small space, making them particularly suitable for a whole range of medical, scientific and small mechanical assembly systems where high performance is required.

The standard MLG rail is available in a range of sizes. For applications where offset loads are present, a wider rail version is available (MLGB type). Both options are part of HepcoMotion's standard stock range.

With rails and blocks made from **stainless steel** as standard, MLG and MLGB miniature guides are also suitable for use in clean rooms.

Both MLG and MLGB types are supplied with the blocks separate to the rails, ready for mounting. For ease of assembly, the balls are retained within the block by means of a wire retaining system.

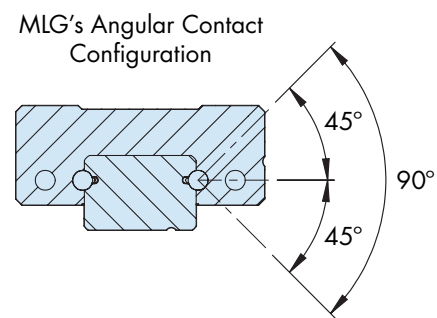
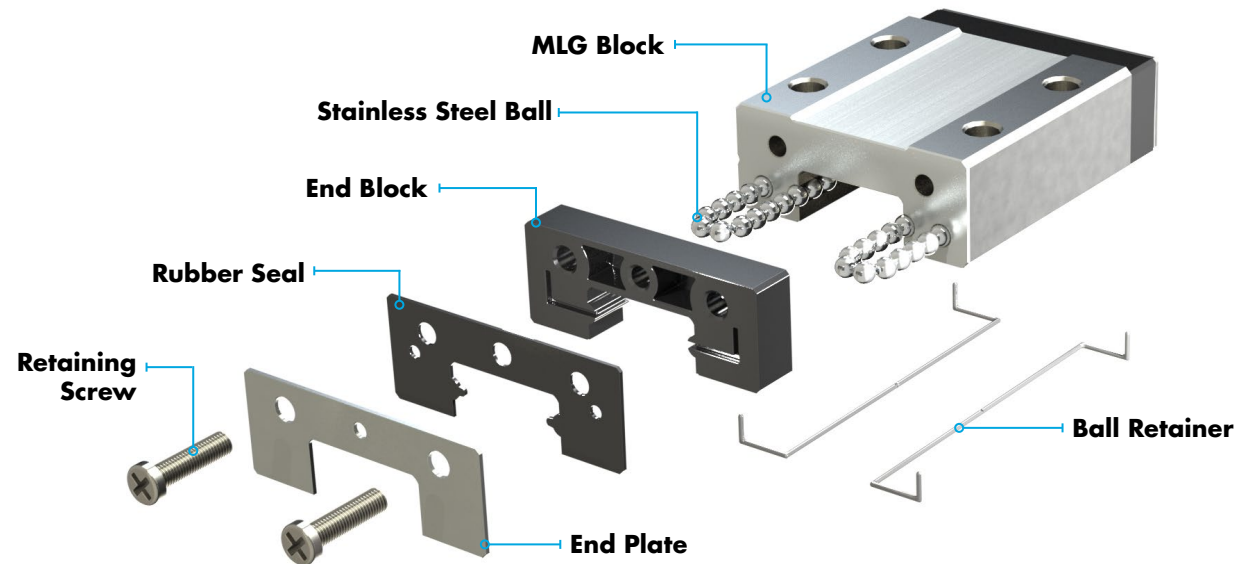





MLG Rail and Block Assembly

Features and Benefits

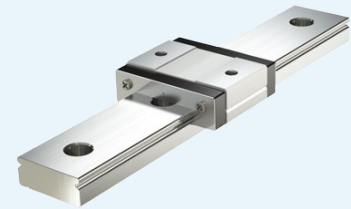
- Comprehensive range of precision and preload grades
- Short lead time available on most popular types
- Competitive prices
- Low deformation under external load provides rigidity
- High speed and low noise
- Stainless steel construction
- Angular contact configuration
- Smooth running

Block Types

MLG Standard Series		MLGB Wide Series	
MLG...C (Short)		MLGB...C MLGB...CE (Short)	
MLG...N (Medium)		MLGB...N MLGB...NE (Medium)	
MLG...L (Long)		MLGB...L MLGB...LE (Long)	

Precision and Preload Options

Hepco offer a full range of sizes with precision and preload grades to meet your particular application requirements. All the options listed are available on a short lead time basis. To enable short delivery lead time, a select range across the most popular sizes, in Normal Precision and 'Z0' Light preload, are held in stock, these are marked with the 'Stock Range'. Normal Precision is ordered using the standard part number, High and Precision grades are ordered with a 'H' and 'P' suffix, respectively.

Rail Accuracy Grades	
Normal	(Stock Range)
H	High
P	Precision

Preload Grades	
Z0	Zero Preload (Stock Range)
Z1	Light Preload

Rail Length Specification

MLG rail is available in any length up to 2000mm, depending on Rail Size. Please see the below table for pitch and maximum length information.

Standard rail lengths are offered in increments of one hole pitch, where the end dimensions 'C' and 'D' are equal and specified. The table below lists the hole pitches and standard end dimensions for the various rail sizes. Rails with custom 'C' and 'D' dimensions are available; simply specify the custom dimensions using the method specified on [3](#).

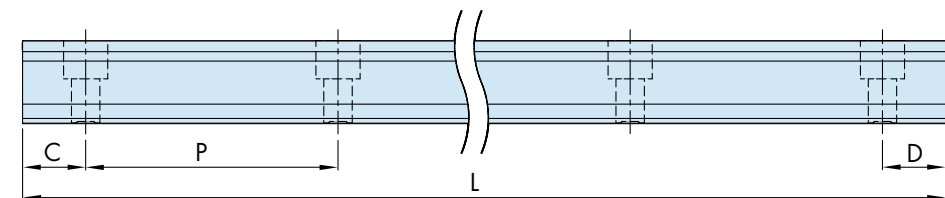

Model No.	MLG Standard Series						MLG...B Wide Series				
	5	7	9	12	15	20	5	7	9	12	15
Standard Pitch P	15	15	20	25	40	60	20	30	30	40	40
Maximum length L	1000	1000	1000	1000	2000	2000	1000	1000	2000	2000	2000

MLG Standard Series blocks have a stainless steel construction and are particularly suitable for applications where space is limited and machine weight is minimised.

Blocks are available in short (MLG...C), medium (MLG...N) and long (MLG...L) versions.

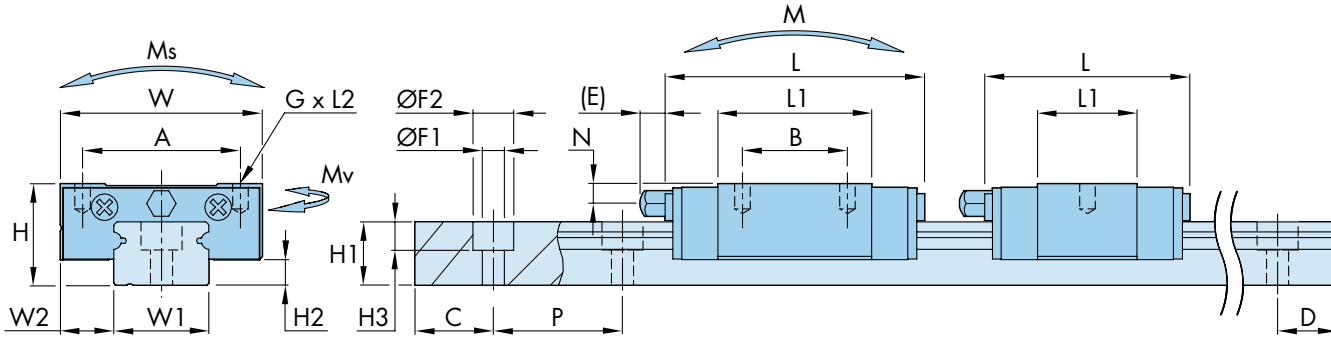

Part Number	Assembly Dimensions (mm)			Dimensions of MLG Block (mm)								Grease Nipple Thread	
	H	H2	W2	L	L1	W	A	B	G x L2	N	E		
MLG 5 C ...	6	1	3.5	17	9.4	12	8	-	M2x1.5	1.2	See Note 1		
MLG 5 N ...				20	12.4			-					
MLG 7 C ...	8	1.5	5	19.8	9.6	17	12	-	M2x2.5	1.5			
MLG 7 N ...				24.3	14.1			8					
MLG 7 L ...				31.8	21.6			13					
MLG 9 C ...	10	2	5.5	22.4	11.8	20	15	-	M3x3	2.2			
MLG 9 N ...				31.3	20.7			10					
MLG 9 L ...				41.4	30.8			15					
MLG 9 LG ...				41.4	30.8			16					
MLG 12 C ...	13	3	7.5	26.4	12.8	27	20	-	M3x3.5	2.7			
MLG 12 N ...				34.9	21.3			15					
MLG 12 L ...				45.4	31.8			20					
MLG 15 C ...	16	4	8.5	34.4	17.7	32	25	-	M3x4	3.1	3.3	M3	
MLG 15 N ...				44.4	27.7			20					
MLG 15 L ...				59.4	42.7			25					
MLG 20 C ...	20	5	10	39.8	22.2	40	30	-	M4x6	4.2	3.3	M3	
MLG 20 N ...				51.8	34.2			25					
MLG 20 L ...				69.8	52.2			30					

Part Number	Dimensions of MLG Rail (mm)					Basic Load Rating (N)		Static Moment Capacity (Nm)*2			Weight	
	W1	H1	C/D	P	F1xF2xH3	C	Co	M(max)	MV(max)	MS(max)	MLG Block (g)	MLG Rail (g/m)
MLG 5 C ...	5 ⁰ _{-0.02}	3.7	6	15	2.4x3.6x0.8	516	757	1.3	1.3	2.0	3.1	139
MLG 5 N ...						631	1009	2.2	2.2	2.7	4.0	
MLG 7 C ...	7 ⁰ _{-0.02}	5	6	15	2.4x4.2x2.3	901	1136	1.9	1.9	4.1	6.4	253
MLG 7 N ...						1197	1703	4.2	4.2	6.2	9.0	
MLG 7 L ...						1631	2650	10.1	10.1	9.7	12.6	
MLG 9 C ...	9 ⁰ _{-0.02}	8	8	20	3.5x6x3.5	1180	1485	3.1	3.1	6.9	9.9	391
MLG 9 N ...						1721	2545	9.3	9.3	11.8	17.1	
MLG 9 L ...						2375	4030	21.9	21.9	18.7	25.2	
MLG 9 LG ...						2375	4030	21.9	21.9	18.7	25.2	
MLG 12 C ...	12 ⁰ _{-0.025}	8	11	25	3.5x6.5x4.5	2175	2385	5.4	5.4	14.8	19.8	679
MLG 12 N ...						3023	3816	14.4	14.4	23.7	31.5	
MLG 12 L ...						4246	6200	34.8	34.8	38.4	45.9	
MLG 15 C ...	15 ⁰ _{-0.025}	10	18	40	3.5x6.5x4.5	3418	3895	12.2	12.2	30.0	37.8	1071
MLG 15 N ...						4540	5842	28.6	28.6	45.0	57.6	
MLG 15 L ...						6492	9737	73.5	73.5	75.0	85.5	
MLG 20 C ...	20 ⁰ _{-0.03}	11	28	60	6x9.5x5.5	4512	5299	20.7	20.7	54.0	80.1	1572
MLG 20 N ...						6191	8328	50.2	50.2	84.9	119.7	
MLG 20 L ...						8396	12870	118.6	118.6	131.3	176.4	

- Notes:**
- MLG5... – MLG12... blocks do not have grease nipples. For more information on lubrication, please speak to our technical sales team.
 - For more details on moment capacity and calculating system life, please see [25](#).

MLG Wide Series blocks have a stainless steel construction and offer higher load capacity than MLG Standard Series blocks. Blocks are available in short (MLGB...C), medium (MLGB...N) and long (MLGB...L) versions.

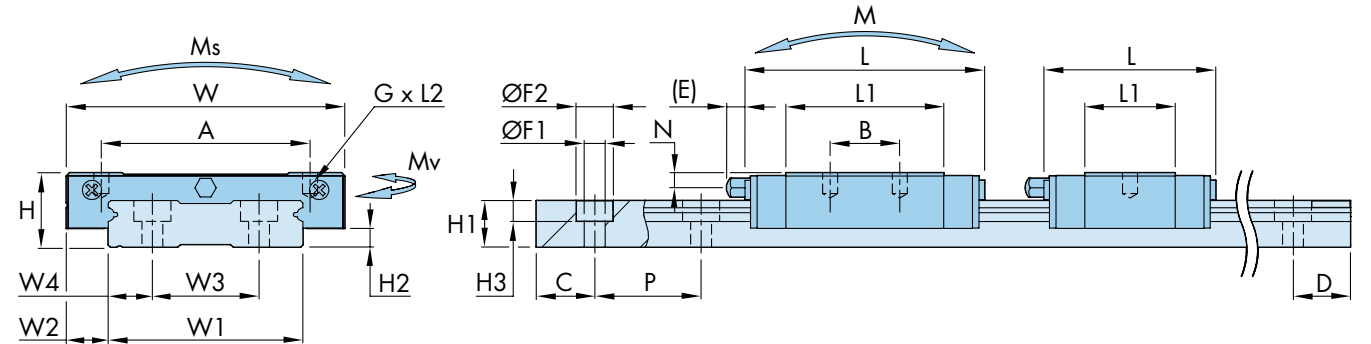

Part Number	Assembly Dimensions (mm)			Dimensions of MLGB Block (mm)								Grease Nipple Thread	
	H	H2	W2	L	L1	W	A	B	G x L2	N	E		
MLGB 5 C ...	6.5	1.3	3.5	21	13.4	17	13	-	M2.5x1.5	1.4	See Note 1		
MLGB 5 N ...				25	17.4			-					
MLGB 7 C ...	9	2	5.5	24	12.6	25	19	-	M3x3	1.7			
MLGB 7 N ...				33	21.6			10					
MLGB 7 L ...				43.5	32.1			19					
MLGB 9 C ...	12	3	6	28.1	16.5	30	21	-	M3x3	3.2			
MLGB 9 N ...				40.2	28.6			12					
MLGB 9 L ...				52	40.4			24					
MLGB 12 C ...				31.1	17.5			-					
MLGB 12 N ...	14	3	8	44.5	30.9	40	28	15	M3x3.5	3.2			
MLGB 12 L ...				59.7	46.1			28					
MLGB 12 CE ...				31.1	17.5			-					
MLGB 12 NE ...	4			44.5	30.9			15		3			
MLGB 12 LE ...				59.7	46.1			28					
MLGB 15 C ...	16	4	9	42.8	25.2	60	45	-	M4x4.5	3.2	4	M3	
MLGB 15 N ...				56.6	39			20					
MLGB 15 L ...				75.8	58.2			35					
MLGB 15 CE ...				42.8	25.2			-					
MLGB 15 NE ...				56.6	39			20					
MLGB 15 LE ...				75.8	58.2			35					

Part Number	Dimensions of MLGB Rail (mm)							Basic Load Rating (N)		Static Moment Capacity (Nm)*2			Weight	
	W1	H1	W3	W4	C/D	P	F1xF2xH3	C	Co	M(max)	MV(max)	MS(max)	MLGB Block (g)	MLGB Rail (g/m)
MLGB 5 C ...	10 ⁰ _{-0.025}	4	-	-	8	20	2.9x4.8x1.6	668	1094	2.6	2.6	5.6	5.3	299
MLGB 5 N ...								806	1430	4.4	4.4	7.4	6.8	
MLGB 7 C ...	14 ⁰ _{-0.05}	5.5	-	-	13	30	3.5x6x3.2	1102	1514	3.4	3.4	10.8	11.7	560
MLGB 7 N ...								1631	2650	10.1	10.1	19.0	18.9	
MLGB 7 L ...								2166	3975	22.5	22.5	28.4	27.9	
MLGB 9 C ...	18 ⁰ _{-0.05}	7	-	-	13	30	3.5x6x4.5	1515	2121	6.2	6.2	19.4	23.4	912
MLGB 9 N ...								2197	3606	18.2	18.2	33.0	39.6	
MLGB 9 L ...								2878	5303	37.8	37.8	48.5	54.9	
MLGB 12 C ...	24 ^{0.05} _{-0.05}	8	-	-	18	40	4.5x8x4.5	2753	3339	10.3	10.3	40.7	40.5	1369
MLGB 12 N ...								4015	5723	31.2	31.2	69.8	68.4	
MLGB 12 L ...								5539	9062	73.8	73.8	110.6	99.9	
MLGB 12 CE ...								2753	3339	10.3	10.3	40.7	40.5	
MLGB 12 NE ...	8.5				18	40	4.5x8x4.5	4015	5723	31.2	31.2	69.8	68.4	2886
MLGB 12 LE ...								5539	9062	73.8	73.8	110.6	99.9	
MLGB 15 C ...	42 ^{0.05} _{-0.05}	10	23	9.5	18	40	4.5x8x4.5	4954	6056	26.9	26.9	128.4	85.5	2886
MLGB 15 N ...								6579	9085	62.5	62.5	192.6	126.0	
MLGB 15 L ...								9076	14384	147.8	147.8	304.9	183.6	
MLGB 15 CE ...								4954	6056	26.9	26.9	128.4	85.5	
MLGB 15 NE ...								6579	9085	62.5	62.5	192.6	126.0	
MLGB 15 LE ...								9076	14384	147.8	147.8	304.9	183.6	

- Notes:**
- MLGB...5 – MLGB...12 blocks do not have grease nipples. For more information on lubrication, please speak to our technical sales team.
 - For more details on moment capacity and calculating system life, please see [25](#).

The HepcoMotion HLG brake provides a compact and simple method of locking an HLG bearing block into position. The brake is intended for manual locking of a stationary block. When the brake is applied, the resulting clamping force does not impose any load upon the bearing block.

Although tailored to suit Hepco HLG Linear Ball Guides, the brake is equally compatible with other ball guide systems, and is manufactured with stainless steel components*¹.

Dimensions for all sizes are given on [19](#). For information on how to select an HLG brake or details on a specific application, please contact Hepco's technical department.

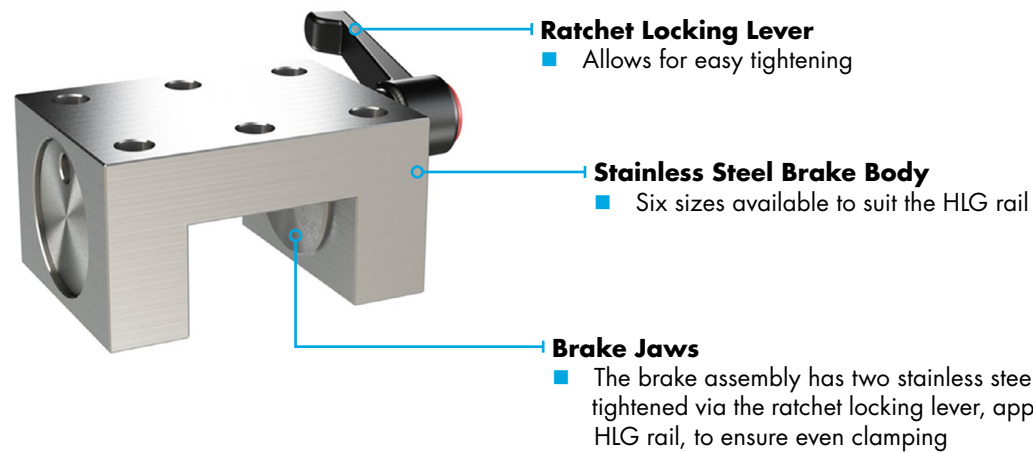

MLG Brake Assembly

Brake assemblies are also available for all sizes of MLG rail. Please contact Hepco for more information on MLG brakes, along with relevant ordering information.



Notes:

- The ratchet locking lever of the HLG15B and HLG20B brakes contain a steel threaded insert and is not available in stainless steel.
- Please note that HLG block and rail are shown for clarity only and are not included as part of the brake assembly.

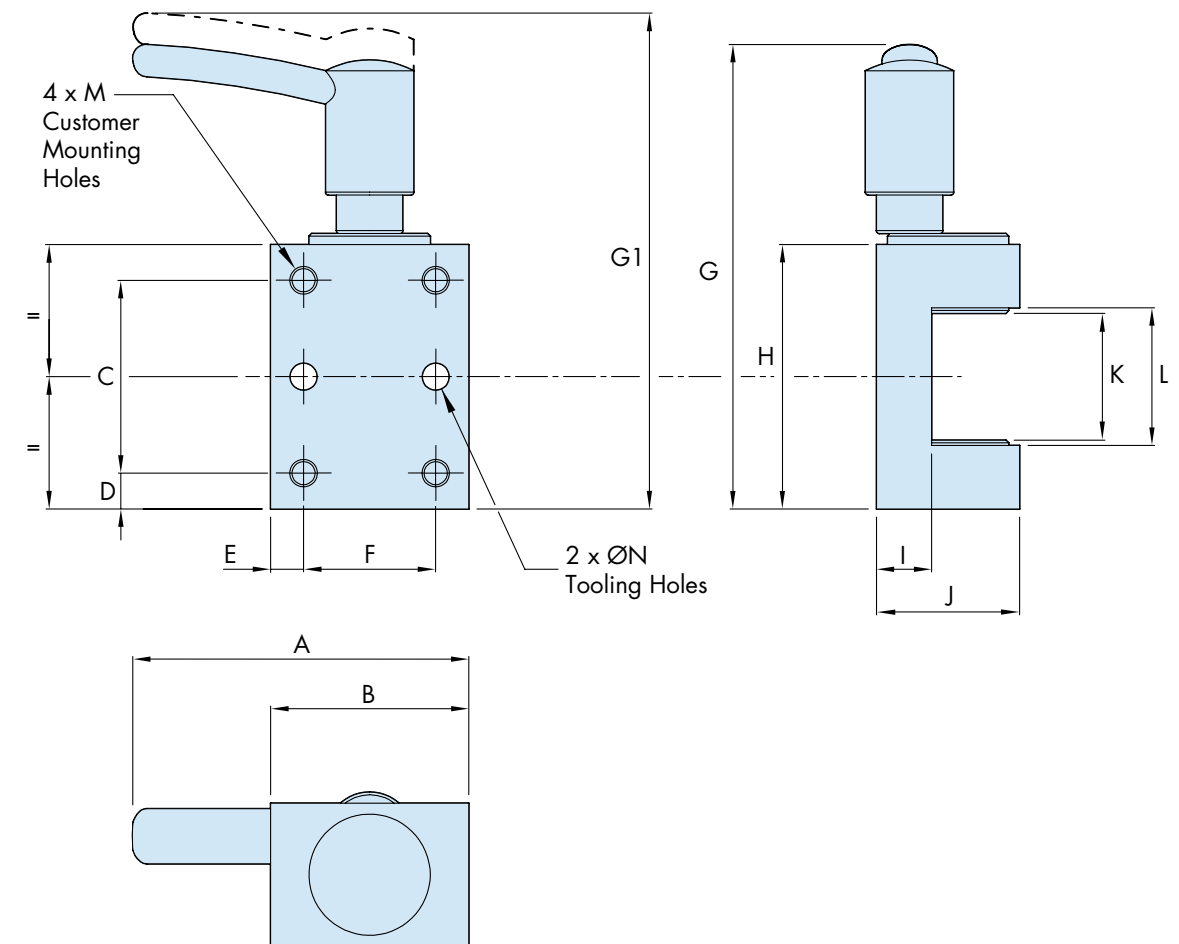

Part Number	For use with HLG rail size	A	B	C	D	E	F	G ⁺¹	G ⁺²	H	I	J	Kmax ⁺²	Kmin ⁺¹	L	M	N
HLG 15 B	15	56	28	22	6	5	18	72	76	34	9	19.5	17	15	17	M4 x 5 Dp	Ø4 x 5 Dp
HLG 20 B	20	58	30	32	6	5	20	82	86	44	9	22	22	20	22	M4 x 5 Dp	Ø4 x 5 Dp
HLG 25 B	25	61	36	35	6.5	6	24	79	83	48	10	26	25	23	25	M5 x 6 Dp	Ø5 x 6 Dp
HLG 30 B	30	85	38	40	10	6.5	25	104	110	60	15	33	30	28	30	M6 x 8 Dp	Ø6 x 7 Dp
HLG 35 B	35	89	46	50	10	7	32	115	121	70	18	38.5	36	34	36	M6 x 8 Dp	Ø6 x 7 Dp
HLG 45 B	45	90	50	60	13	8	34	132	138	86	21	46	47	45	47	M6 x 8 Dp	Ø6 x 7 Dp

Ordering Details

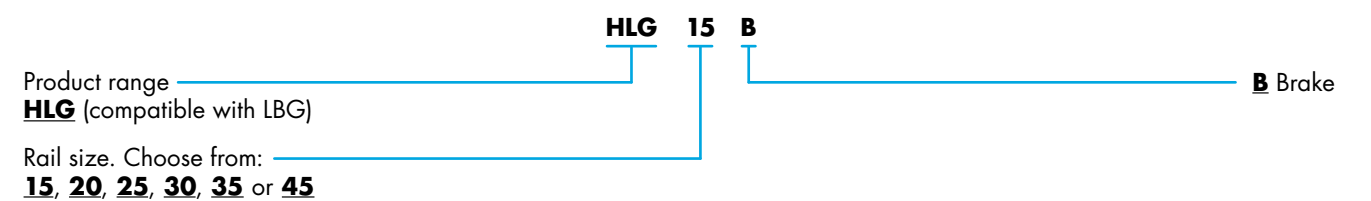

Notes:

- Dimensions G and Kmin are measured with the brake fully tightened against the rail.
- Dimensions G1 and Kmax are measured with the brake released and the handle in the disengaged position.

HLG recirculating ball guides require effective lubrication to be present within the block at all times to prevent premature wear. Blocks should be lubricated with a suitable grease or oil. In most industrial applications, grease is commonly used due to the longevity between re-lubrication intervals and cleanliness factors.

Oil-based lubrication normally requires an automatic lubrication system to be installed for maximum effect. For normal applications, lithium soap based greases are commonly used but synthetic greases are also acceptable. The re-lubrication interval can be affected by environmental and other service conditions but is generally after 100km of travel.

Bleed Lubrication

Re-lubricating ball rail blocks via the integrated grease nipple is the preferred method of lubrication, due to its simplicity. However, where access is restricted, or when automation is required, bleed lubrication provides an alternative, low maintenance way of lubricating blocks. Blocks are moved to a maintenance position over lubrication passages drilled into the guide rail.

The blocks can then be charged remotely through pipe work fitted to the carriage via a grease gun or an automatic dosing pump.

The bleed lubrication option is available on all HLG ball rails.

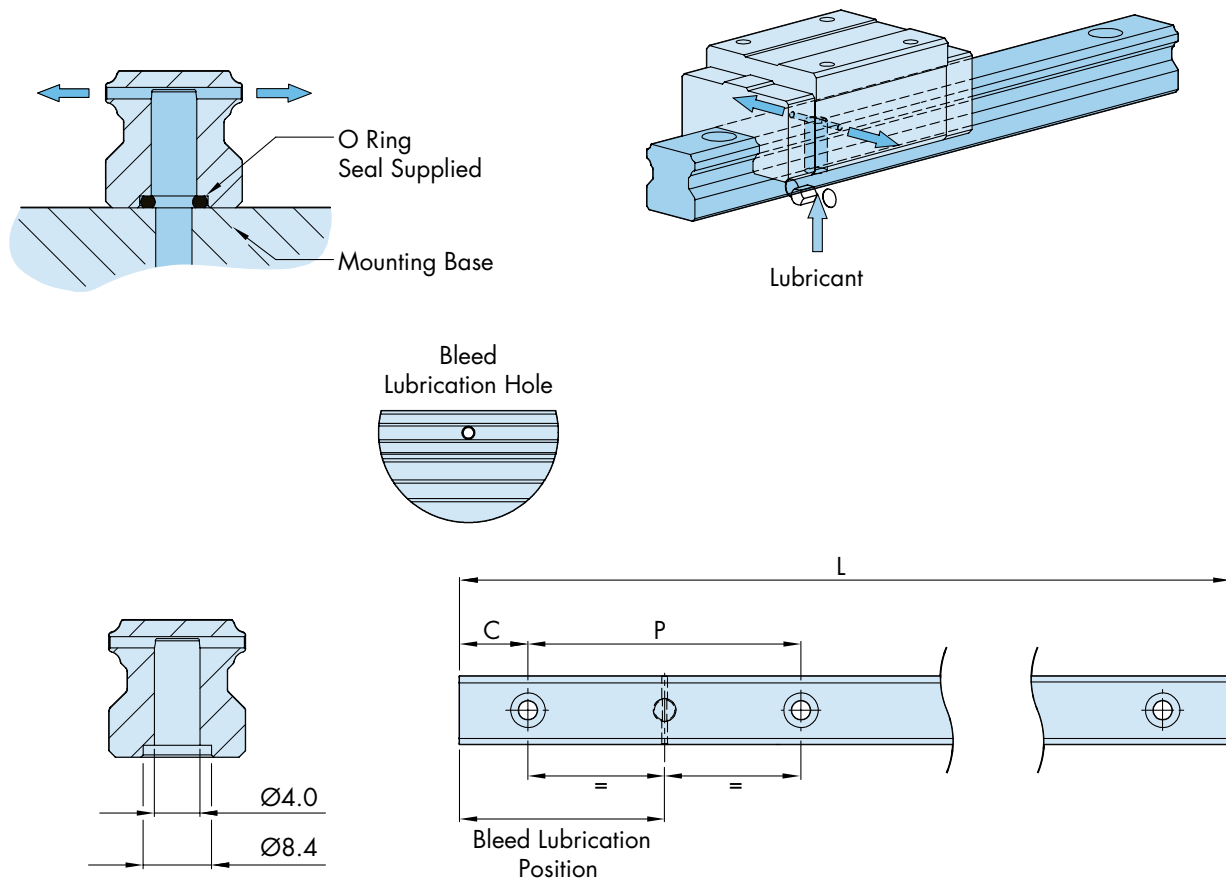

Ordering Details

The standard position of the single bleed lubrication feature will be midway between the first and second holes at one end of the rail, as illustrated above. For multiple or specific positions of the bleed lubrication feature, please provide a detailed drawing to our sales team.

Ordering Example:

HLGBL25L1256C28D28

Please refer to [28](#) for specific ordering information.

Surface Treatment

HLG recirculating ball guides are available with a number of corrosion resistant treatments, depending on application requirements and cost. For corrosion protection, Pristinox B is a low temperature black coating that has proved to work equally well in clean rooms and in conditions where the rail is subject to water spray. In all applications where water is present, it is recommended to conduct a short trial in the installation to ensure that the requirements can be met. We can assist with the supply of samples for test purposes. Please contact our sales department for further advice on applications requiring corrosion resistance.

Sealing Options

Please see the table below for information on the various sealing arrangements for both HLG and MLG. Rail hole caps are provided as standard on all HLG rail orders. Additional protective scrapers are available to further reduce the ingress of dirt and debris. Please contact Hepco for more information.

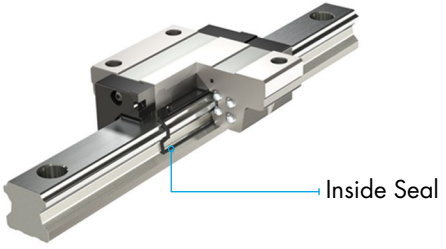
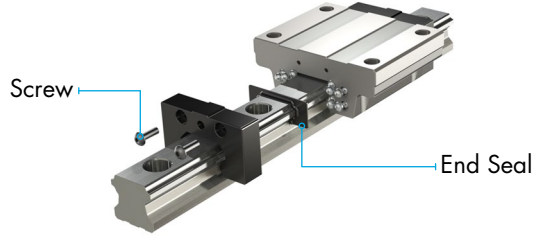
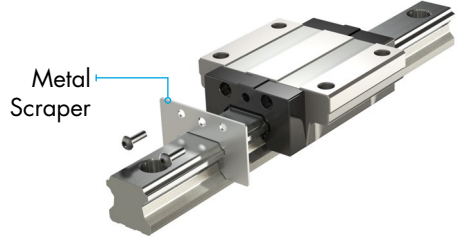
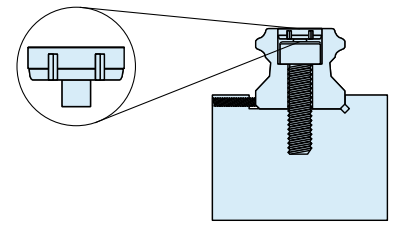
Feature	Seal Positions	Description
Inside Seal		Applicable to HLG Standard Series. This is a combined end and side seal.
End Seal		Applicable to all MLG Series.
Metal Scraper		Optional scraper for the HLG range, for removing dirt and particles from the rail surface and improving system life. Part Number: HLGAMS... for use with "A" Series Block HLGMS... for use with non "A" Series Block Refer to 5 for more information
Rail Cap		Cap to prevent dirt entering mounting holes. Supplied with each rail length order (HLG only).

HLG Precision

HLG rail and blocks are available in various grades of precision. Please see [2](#) & [15](#) for more information.

The accuracy of travel of HLG recirculating ball guides is measured as shown in the diagram below. Tolerance data is provided in the table below for HLG, and in the table on [23](#) for MLG.

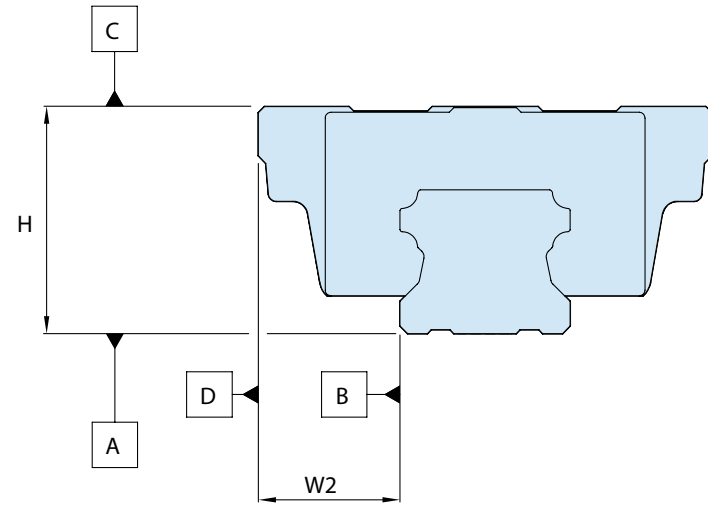

Tolerance (mm)	Normal	High	Precision	Super Precision	Ultra Precision
	No symbol	H	P	SP	UP
Height (H) tolerance	±0.080	±0.042	±0.020	±0.010	±0.008
Block to block height (H) variation tolerance*1	0.025	0.015	0.007	0.005	0.003
Width (W2) tolerance	±0.100	±0.050	±0.025	±0.015	±0.010
Block to block width (W2) variation tolerance*1	0.030	0.020	0.010	0.007	0.003

Running Parallelism of HLG blocks

The graph below shows the maximum variation of H and W2 as a block runs along the length of a rail. This parallelism is shown in micrometers for the various grades of precision. Parallelism is measured from parallel datums, i.e from block datum C to rail datum A, and from block datum D to rail datum B.

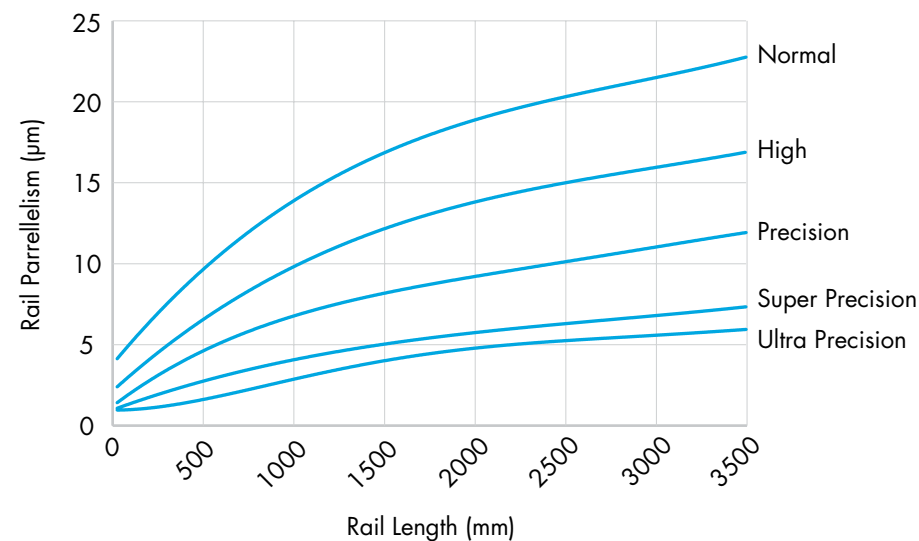

Notes:

1. Block to block tolerance refers to blocks mounted on the same rail.

MLG Precision

Model Size	Tolerance (mm)	Normal	High	Precision
		No symbol	H	P
5	Height (H) tolerance	±0.030	-	±0.015
	Block to block height (H) variation tolerance*1	0.015	-	0.005
	Width (W2) tolerance	±0.030	-	±0.015
	Block to block width (W2) variation tolerance*1	0.015	-	0.005
7 - 20	Height (H) tolerance	±0.040	±0.020	±0.010
	Block to block height (H) variation tolerance*1	0.030	0.015	0.007
	Width (W2) tolerance	±0.040	±0.025	±0.015
	Block to block width (W2) variation tolerance*1	0.030	0.020	0.010

Running Parallelism of MLG blocks

The graph below shows the maximum variation of H and W2 as a block runs along the length of a rail. This parallelism is shown in micrometers for the various grades of precision. Parallelism is measured from parallel datums, i.e from block datum C to rail datum A, and from block datum D to rail datum B.

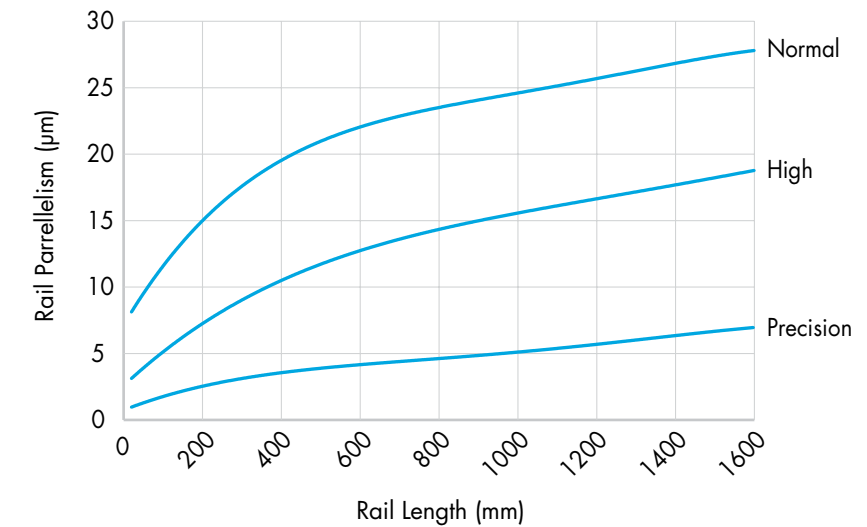

HLG Preload Data

HLG recirculating ball guides are supplied in four preload levels. The function of preload is to eliminate clearance between the block and rail running surfaces, by the insertion of a ball larger than the space available.

The rigidity of the block is a function of the preload level. In normal applications, Z0 (zero / light preload) or Z1 (light preload) will suffice. For higher duty applications, subject to high moment loads, Z2 is most suitable (medium preload).

The equivalent preload force is the force being applied within an individual block, caused by the elastic deformation of the steel balls, where 'C' is the Basic Dynamic Load Rating.

Type	Preload Type	Preload Type	Equivalent Preload Force
HLG	Z0	Zero / Light (Stock Range)	0 – 0.03 x C
	Z1	Light (Stock Range)	0.04 – 0.08 x C
	Z2	Medium	0.09 – 0.13 x C
HLGS	Z0	Zero / Light (Stock Range)	0 – 0.03 x C
	Z1	Light (Stock Range)	0.03 – 0.05 x C
	Z2	Medium	0.06 – 0.08 x C

Notes:

1. Block to block tolerance refers to blocks mounted on the same rail.

Friction

The frictional resistance of a system is determined using the following equation:

$$F = \mu \times P + f_s$$

where
 F = frictional resistance (N)
 μ = coefficient of friction (see graph below)
 P = applied load (N)
 C = basic dynamic load rating (N)
 f_s = seal resistance (N) (see table below)

Coefficient of Friction, μ

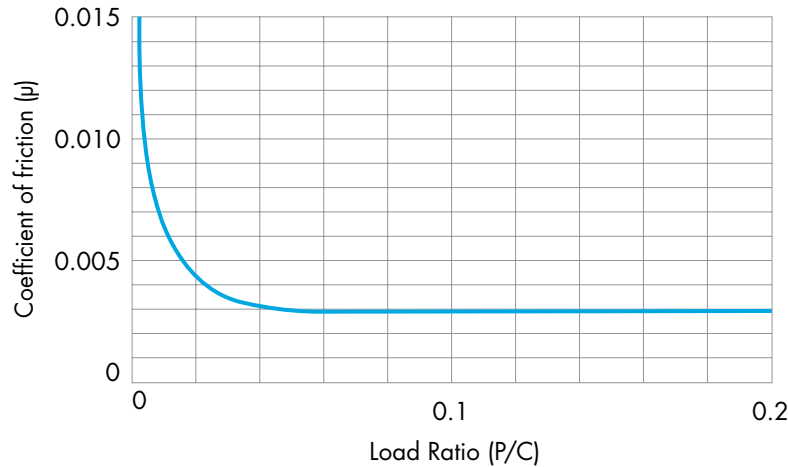

Seal Resistance per block, f_s

Rail Part Number	Seal Resistance per block (N), f _s
HLG 15	2
HLG 20	4
HLG 25	4
HLG 30	6
HLG 35	11
HLG 45	19
HLG 55	19

Static Load Capacity

Basic Static Load Rating, C₀

Excessive static loads can cause permanent deformation of the rolling element and raceway surface. The static load rating, C₀, is the static load, of constant magnitude, and acting in one direction, the static load rating is exceeded, permanent deformation of the element and raceway surface equivalent to 0.0001 times the ball diameter will occur.

Static Safety Factor, f_a

A static safety factor (f_a) should be taken into account in relation to the basic load rating (C₀) and operating condition. The table below provides a recommended range of static safety factors (f_a):

Operating Condition	Static Safety Factor, f _a
No vibration or shock loads	1.0 – 1.5
Vibration and/or shock loads present	1.5 – 2.0
Extreme vibration and/or shock loads	2.5 – 7.0

The basic dynamic load rating of linear guides, C, is based on a constant, one directional load that provides 50km of linear travel. This is the distance at which 10% of guides will show signs of fatigue, pitting of the block or rail tracks, necessitating replacement.

Calculating the Equivalent Dynamic Load

Loads and moments should be combined as per the equation below. In accordance with ISO 14728-1, P should not exceed 1/2 x C.

$$P = L_1 + L_2 + \left[\frac{M_s}{M_{s(max)}} + \frac{M_v}{M_{v(max)}} + \frac{M}{M_{(max)}} \right] \times C_0$$

where
 P = equivalent dynamic load (N)
 L₁ = applied vertical load (N)
 L₂ = applied horizontal load (N)
 M_s = applied M_s moment load (Nm)
 M_v = applied M_v moment load (Nm)
 M = applied M moment load (Nm)
 M_{s(max)} = static M_s moment capacity (Nm)
 M_{v(max)} = static M_v moment capacity (Nm)
 M_(max) = static M moment capacity (Nm)
 C₀ = static basic load rating (N)
 C = basic dynamic load rating (N)

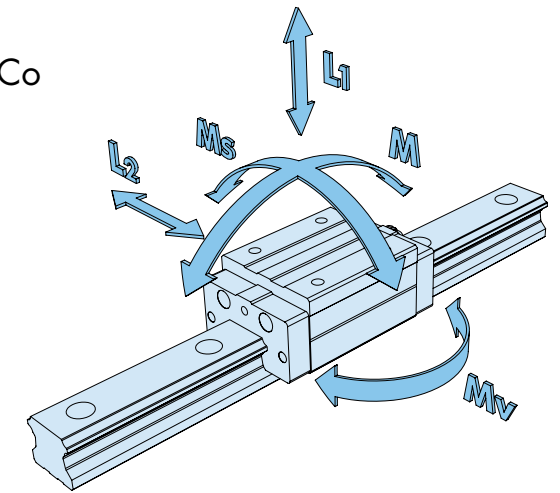

Calculating System Life

The 50km travel load rating is used to calculate the life of the system under normal operating conditions.

Factors should be applied to the calculation where necessary:

- If two or more blocks are used on the same rail, refer to the Mounting Factor (f_c) table below.
- If additional forces from vibration or impact are being applied, refer to the Variable Load Factor (f_v) table below.

Other factors that will affect system life but not considered in the calculation include:

- Excess load by inaccurate assembly
- Contamination within the block
- High speed, short stroke motion with excessive load
- Damage to the end plates
- Lack of lubrication

$$L = \left[\frac{f_c \times C}{f_v \times P} \right]^3 \times 50$$

where
 L = fatigue life (km)
 C = basic dynamic load rating (N)
 P = applied load (N)
 f_c = mounting factor (see table below)
 f_v = variable load factor (see table below)

Mounting Factor, f_c

Where two or more blocks are used in close proximity, multiply the stated basic load rating (C) by the mounting factor (f_c):

Number of blocks	Mounting Factor, f _c
2	0.81
3	0.72
4	0.66
5	0.61
Over 6	0.60

Variable Load Factor, f_v

In cases where additional forces from vibration or impact are applied, multiply the applied load (P) by the variable load factor (f_v):

Operating Condition	Speed	Variable Load Factor, f _v
No external impact or vibration	Less than 0.25 m/s	1.0 – 1.2
Moderate impact and/or vibration	0.25 m/s – 1 m/s	1.2 – 1.5
Strong impact and/or vibration	1 m/s – 2 m/s	1.5 – 2.0
	Greater than 2 m/s	2.0 – 4.0

The following tables provide dimensional installation data for HLG and MLG block and rail assemblies. All dimensions in the table below are in millimetres.

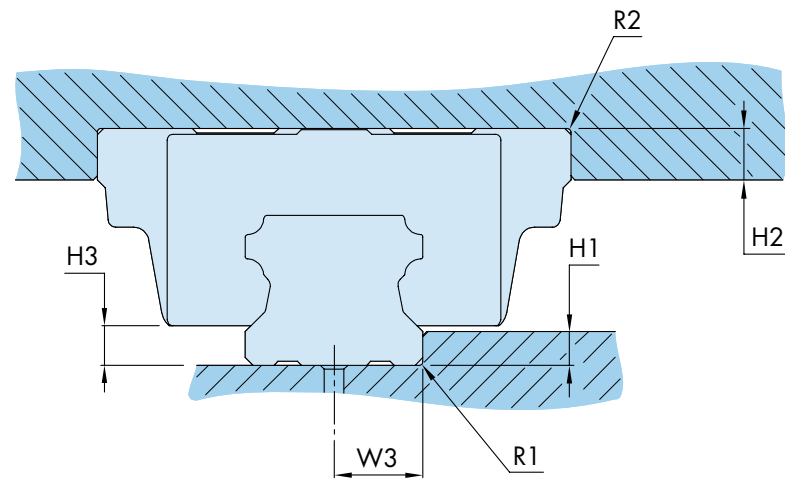

Series	Size	R1 (max)	R2 (max)	H1	H2	H3
HLG...	...15...	0.5	0.5	3	4	4.7
	...15...A	0.5	0.5	3	4	4.5
	...20...	0.5	0.5	3.5	5	5
	...25...	1	1	5	5	7
	...30...	1	1	5	5	7.5
	...35...	1	1	6	6	9
	...45...	1	1	8	8	10
...55...	1.5	1.5	10	10	13	
HLGS...	...15...	0.5	0.1	2.5	4.0	4.5
	...20...	0.5	1.0	4.0	5.0	6.0
	...25...	1.0	1.0	5.0	5.0	7.0
MLG... MLGB...	...5...	0.2	0.2	0.8	2	1
	...7...	0.2	0.2	1.2	2.5	1.5
	...9...	0.2	0.2	1.5	3	2
	...12...	0.2	0.2	2.5	4	3
	...12...E	0.2	0.2	2.5	4	4
	...15...	0.2	0.2	3	4.5	4
...20...	0.2	0.2	4	5	5	

Rail lengths for HLG recirculating ball guides are supplied in lengths up to 4000mm in one piece, except for the miniature series (please see [15](#) for individual lengths). Longer lengths are supplied as butted sets, maintaining a constant hole pitch across the joint.

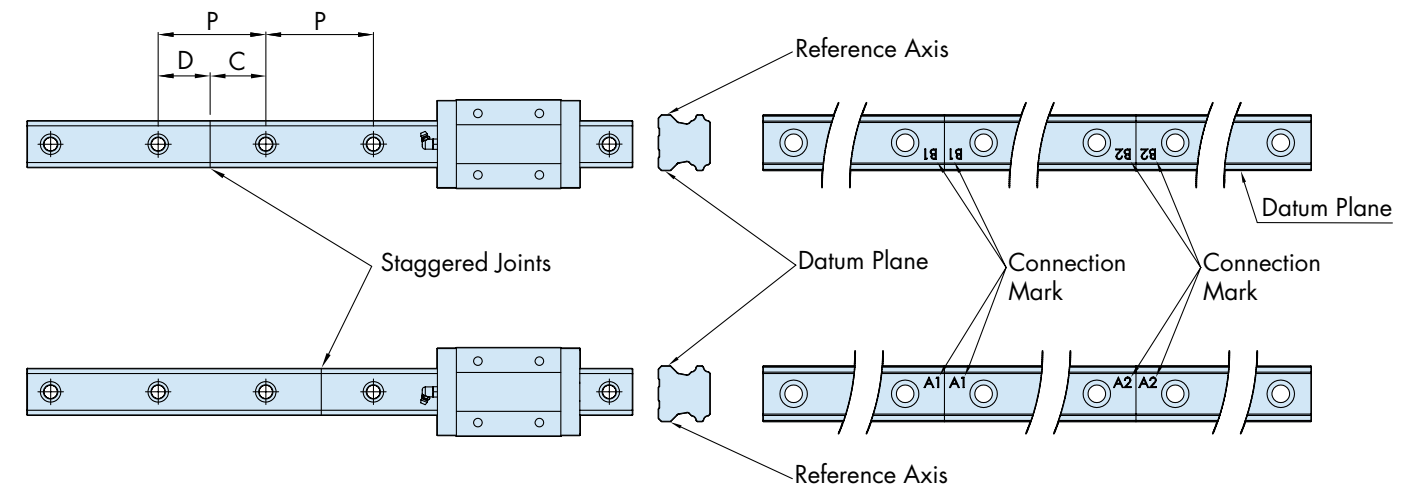

Block Installation

HLG blocks are supplied on a plastic guide rail to ensure that the internal balls remain within the recirculating system whilst in transit, and for ease of assembly.

It is important to align the end of the plastic guide rail to the rail and carefully slide the block on to the rail. Incorrect alignment could result in damage to the balls or loss of balls from the recirculating system.

The block should move freely on the rail, with no rough spots. Rough running is a sign that contamination has occurred or balls have been accidentally released during the assembly process. Please contact Hepco's technical department for assistance or further information on block installation.



HLG Ordering Details

Using the following part number configuration allows the correct specification of HLG rail and block to be ordered. Please contact Hepco's sales department to place an order or make an enquiry.

HLG Block

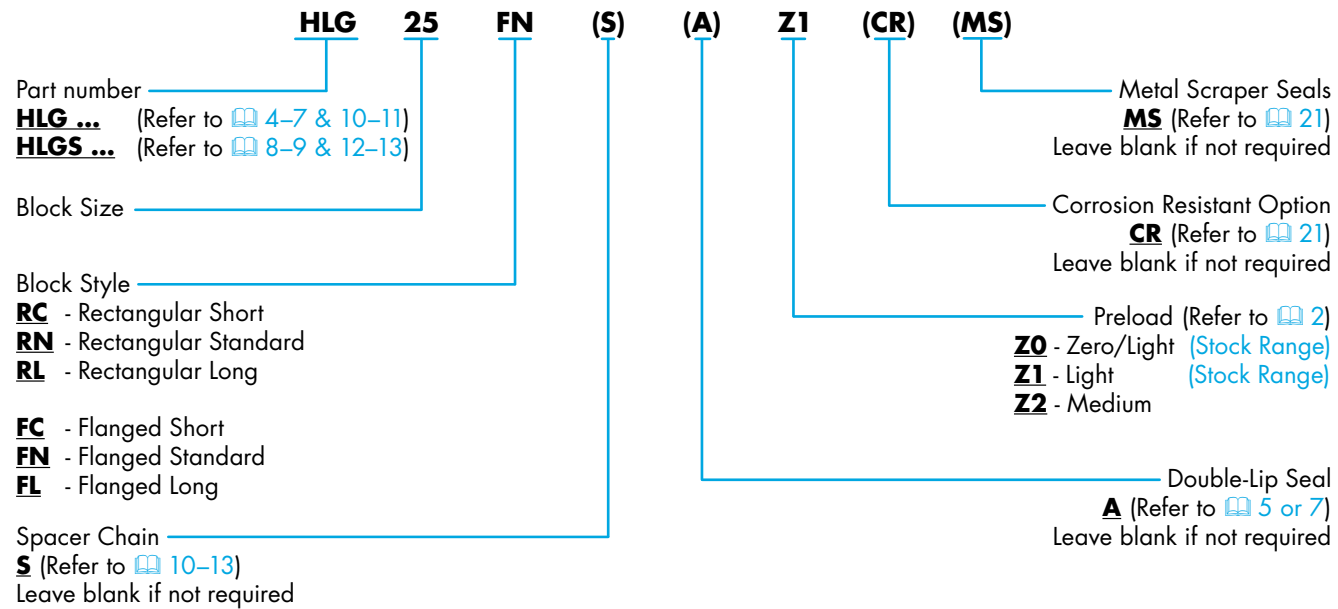

HLG Rail

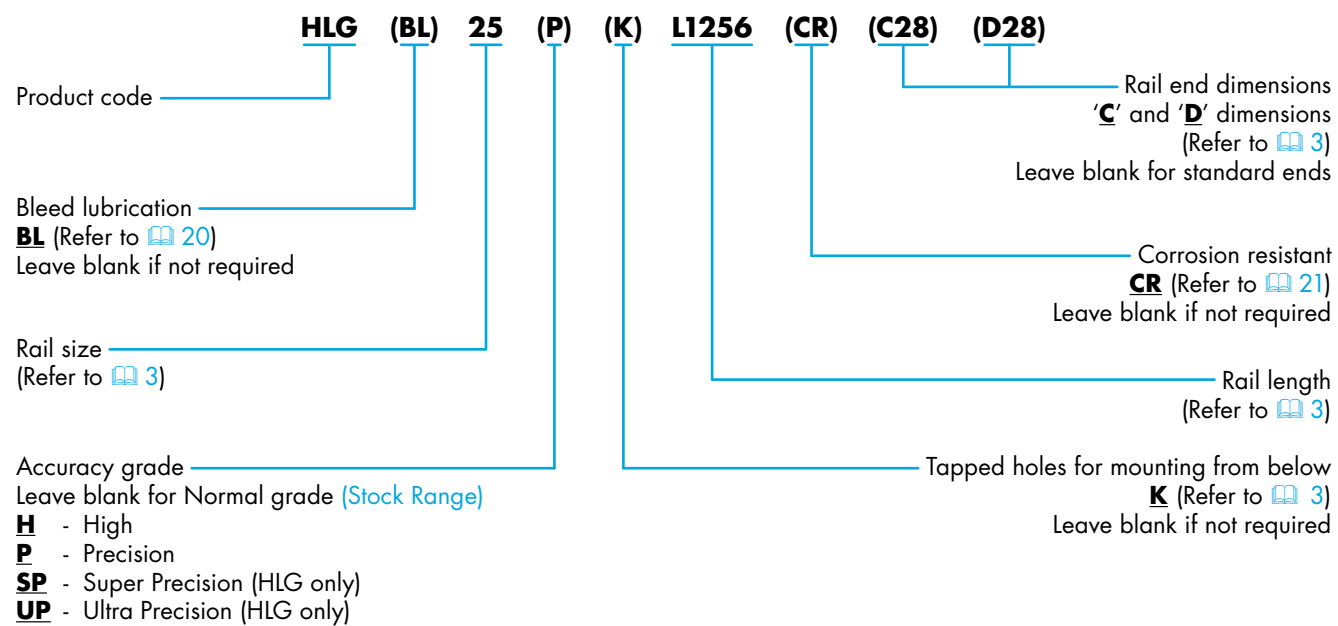

MLG Ordering Details

Using the following part number configuration allows the correct specification of MLG rail and block to be ordered. Please contact Hepco's sales department to place an order or make an enquiry.

MLG Block

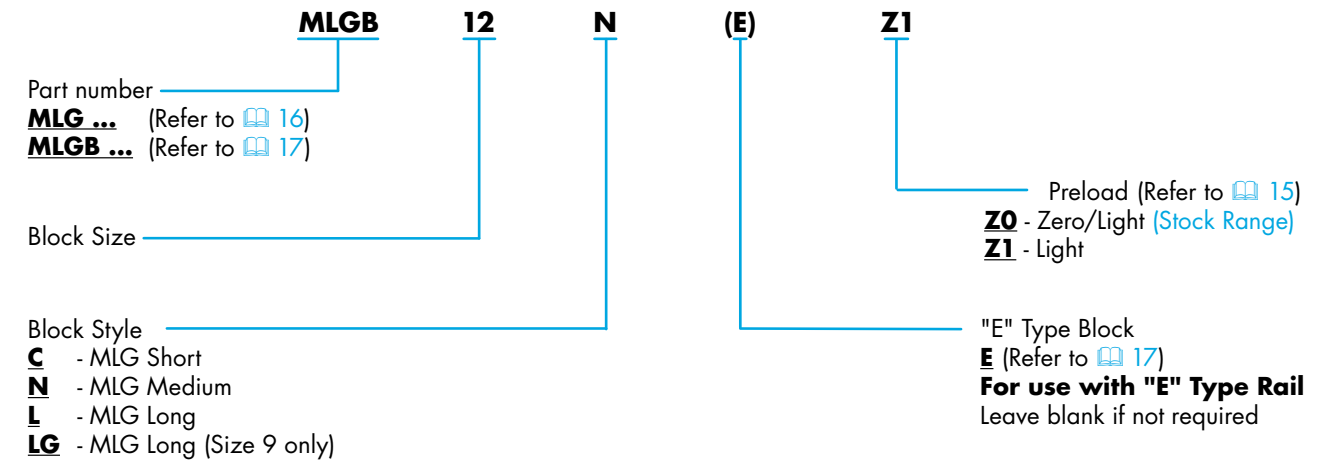

MLG Rail

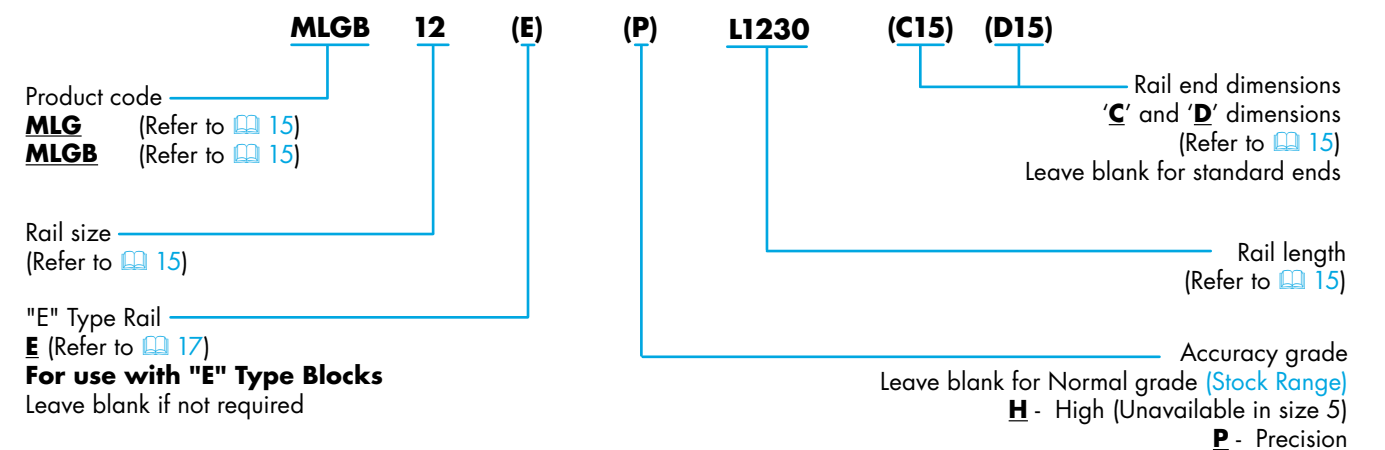

CATALOGUE No. HLG 02.10 UK © 2024 Hepco Slide Systems Ltd.

Reproduction in whole or part without prior authorisation from Hepco is prohibited. Although every effort has been made to ensure the accuracy of the information in this catalogue, Hepco cannot accept liability for any omissions or errors. Hepco reserves the right to make alterations to the product resulting from technical developments.

Many Hepco products are protected by: Patents, Copyright, Design Right or Registered Design. Infringement is strictly prohibited and may be challenged in law. The Customer's attention is drawn to the following clause in Hepco's conditions of sale:

'It shall be the Customer's sole responsibility to ensure that goods supplied by Hepco will be suitable or fit for any particular application or purpose of the Customer, whether or not such application or purpose is known to Hepco. The Customer will be solely responsible for any errors in, or omissions from, any specifications or information the Customer provides. Hepco will not be obliged to verify whether any such specifications or information are correct or sufficient for any application or purpose.'

Hepco's full conditions of sale are available on request and will apply to all quotations and contracts for the supply of items detailed in this catalogue.

HepcoMotion is the trading name of Hepco Slide Systems Ltd.

HepcoMotion®

ADVANCED LINEAR SOLUTIONS



GV3

Linear Guidance and Transmission System



HDS2

Heavy Duty Slide System

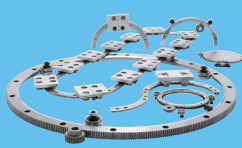

PRT2

Ring Slides and Track System

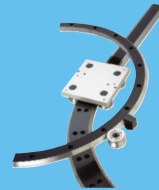

HDRT

Heavy Duty Ring Slides and Track System

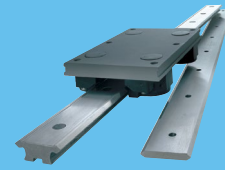

SL2

Stainless Steel Based Slide System

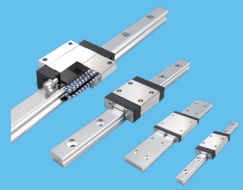

HLG

Hepco Ball Guides

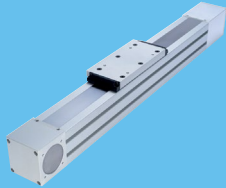

SBD

Sealed Belt Drive

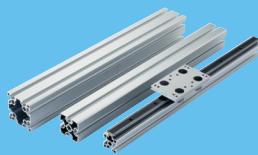

MCS

Aluminium Frame and Machine Construction System

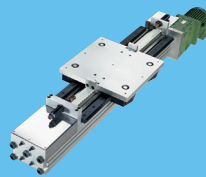

HDLS

Heavy Duty Driven Linear System

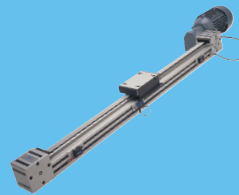

DLS

Linear Transmission and Positioning System

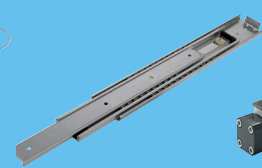

HTS

Telescopic Ball Bearing Slides



HPS

Powerslide-2 Guided Rodless Cylinder

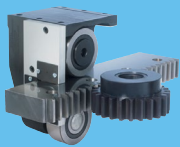

MHD

Heavy Duty Track Roller Guidance System

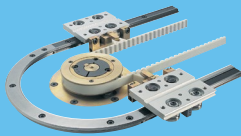

DTS

Driven Track System

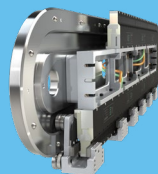

GFX

Hepco Guidance System for Beckhoff XTS



HBS

Ball Screw Assemblies

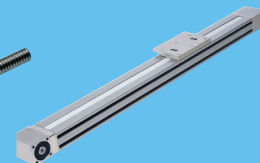

PDU2

Profile Driven Unit

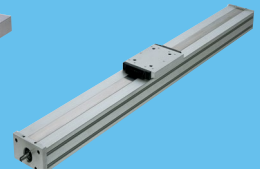

PSD120

Profile Screw Driven Unit



SHAFT

Precision Steel and Aluminium Shaft

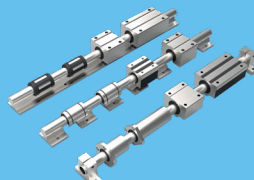

BALL BUSHINGS

Linear Bearing System



DUALVEE®

Single Edge Slide System

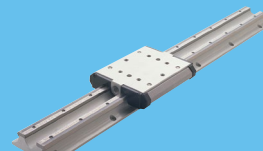

LoPro®

Aluminium Based Slide System

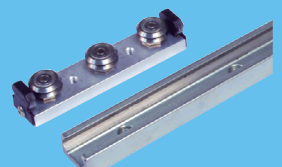

UtiliTrak®

Lightweight U Channel Guideway

For further information on HepcoMotion® products and details of worldwide representation, please visit:

HepcoMotion.com

HepcoMotion Group Headquarters

www.hepcotion.com

Lower Moor Business Park
Tiverton Way, Tiverton
EX16 6TG
England

Tel: +44 (0)1884 257000
E-mail: sales@hepcotion.com

HepcoMotion Germany

(Also covering Austria & German-speaking Switzerland)

www.hepcotion.com/de

Tel: +49 (0) 9128 92710
Email: info.de@hepcotion.com

HepcoMotion Spain

www.hepcotion.com/es

Tel: +34 93 607 22 55
Email: info.es@hepcotion.com

HepcoMotion France

(Also covering French-speaking Switzerland)

www.hepcotion.com/fr

Tel: +33 (0)1 34 64 30 44
Email: info.fr@hepcotion.com

HepcoMotion South Korea

www.hepcotion.co.kr

Tel: +82 (0) 31 352 7783
Email: sales.korea@hepcotion.com

HepcoMotion Benelux

(Covering Belgium, Luxembourg & Netherlands)

www.hepcotion.com/nl

Tel: +31 (0) 492 551290
Email: info.nl@hepcotion.com

HepcoMotion China

www.hepcotion.com.cn

Tel: +86 21 5648 9055
Email: sales.china@hepcotion.com



Certification Number 14479
ISO 9001