

# HepcoMotion®

## **PDU2M**

Belt driven unit  
for moment loads

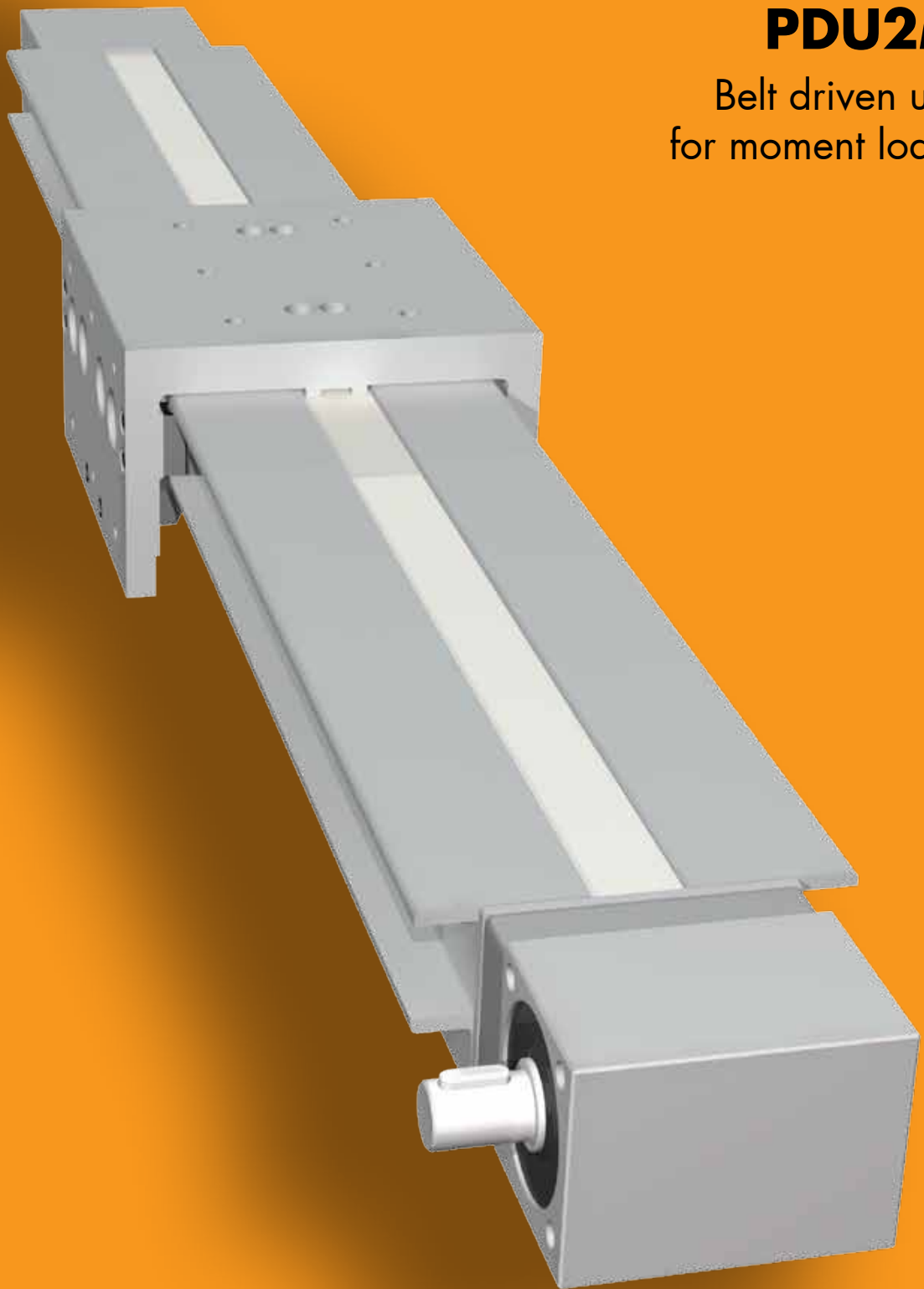

# Introduction

The HepcoMotion® **PDU2M** is a new addition to the popular PDU2 range of belt driven linear units.

It shares all of the key features and benefits of the PDU2 but with increased load capacity and stiffness.  $L_1$  load capacity is 50% higher,  $M_s$  moment load capacity is 200% higher, and  $M_s$  stiffness is improved ten fold.

These improvements make the PDU2M particularly suitable for use in multi-axis systems, as well as in demanding single-axis applications.

The unit is available with a number of carriage designs which allow the quick and easy construction of multi-axis systems with a minimal requirement for brackets and hardware.

The PDU2M unit is essentially a modified PDU2 unit, and many details of the two products are the same. This document should be read in conjunction with the PDU2 catalogue (available at [www.HepcoMotion.com/pdu2datauk](http://www.HepcoMotion.com/pdu2datauk)) to provide full information on the unit.

## Carriage

High load capacity - up to 750N and 15Nm  
10 times torsional stiffness of PDU2  
High speed - Up to 6m/s  
Long life with no re-lubrication  
Multiple on a single unit available

## Internal Buffer

End of stroke protection at both ends.

## Hepco Herculane® Wheels

Ultra-high performance wheels mounted on adjustable eccentric studs

## Aluminium Beam

Rigid & lightweight  
T-slots in underside

## Toothed Belt Drive

20AT3 belt gives driving forces up to 280N

## Several carriage styles

To suit single axis and multi-axis applications

## Limit Switch Cam

## Felt wipers

Sweep debris away from the path of the Herculane® wheels

## Limit switch & Bracket

Mechanical & Inductive versions available.  
IP67 rating.  
Switches attach to T-slot under the beam and can be positioned anywhere along it.

## Shaft configurations

Units have left, right or double shafts (right shown)  
All standard PDU2 motor connection kits will fit.

The unit shown has a right-handed shaft and a right-handed carriage

# Data & Dimensions

The main dimensions of the PDU2M are shown in the drawing below. Further details can be obtained from the 2D and 3D CAD files, available from [www.HepcoMotion3dcad.com](http://www.HepcoMotion3dcad.com).

Hepco's Technical Department is on hand to assist with application enquiries or to undertake the design of complete mechanical systems.

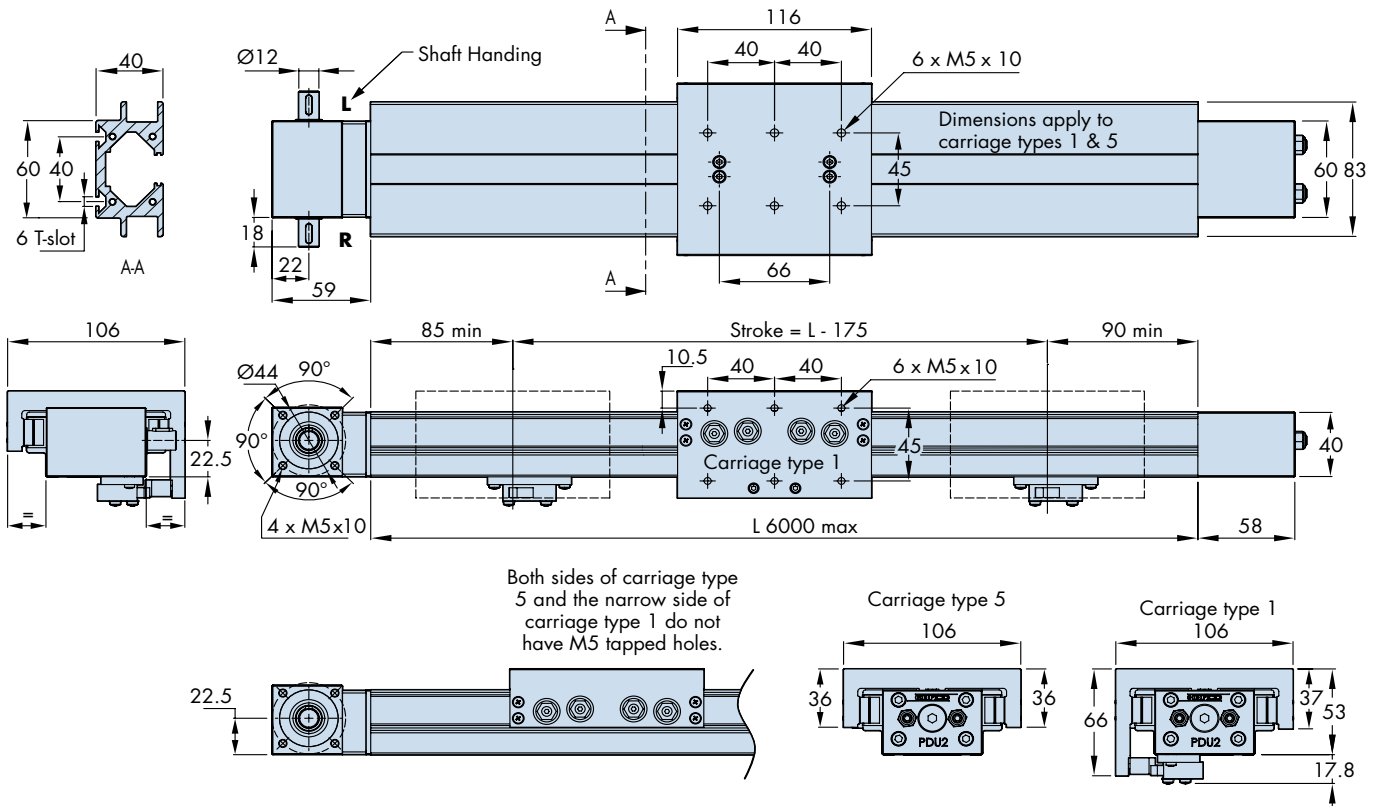

The weight of a PDU2M unit in kg = 1.9 + 3.36 x L (where L = beam length in m).

The above drawings show PDU2M units with carriages of type 1 & type 5.

Carriage type 1 is the "general purpose" design. Note that the carriage wraps around the beam and the limit switches are mounted under the beam. This is suitable in applications where the unit spans a gap and is supported at the ends.

Carriage type 5 does not extend below the underside of the beam and thus can be used when the PDU2M beam is supported along its length. This type does not have a switch cam facility.

Other carriage types are similar to type 1, and are designed for specific types of multi-axis connection (see next page.)

## Service Interval Calculations

After very long service, slight play in the carriage may develop. This can be corrected by re-adjusting the carriage, which will return the unit to its original condition. Adjustment is quick and simple and may be repeated several times.

The table shows the maximum carriage loading, and the calculation below determines the service interval.

Hepco will provide more data and carry out calculations for your application, on request.

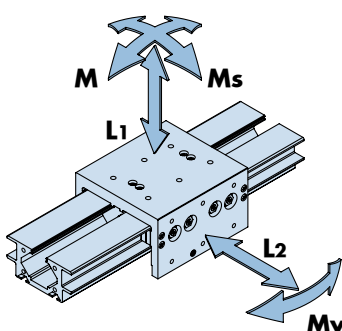

Carriage Load Capacity				
L1	L2	Ms	Mv	M
750N	500N	15Nm	14Nm	21Nm

To determine service interval, first calculate the load factor  $L_F$  using the equation below.

$$L_F = \frac{L_1}{L_{1(max)}} + \frac{L_2}{L_{2(max)}} + \frac{M_S}{M_{S(max)}} + \frac{M_V}{M_{V(max)}} + \frac{M}{M_{(max)}} \leq 1$$

$$\text{Service Interval (km)} = \frac{5000}{(0.25 + 0.75 \times L_F)} \quad \text{Note: life will be several times this service interval}$$

# How to order

The ordering information below is given to assist communication, but you are recommended to discuss your application with Hepco first so that we can help to specify the best unit to suit your needs.

## Main Unit

**PDU2M L2468 R T DC 2 L**

Product range = **PDU2M**

**L2468** = beam length in mm (max 6000). Note that stroke length is 175mm shorter.

Shaft Handing **R** = right handed, **L** = left handed, **D** = double shaft (see picture below for example)

**T** = beam with T-slots (this is the only option at present)

**DC** = (belt) driven carriage (this is the only option at present)

Carriage Type Number: select **1**, **3** or **5** (type 3 shown below, types 1 & 5 on previous page)

Carriage Handing **R** = right handed, **L** = left handed (see picture below for example)

## Ancillary Components

T-nuts, T-slot covers, motor connection kits, gearboxes and limit switches from the PDU2 catalogue (available at [www.HepcoMotion.com/pdu2datauk](http://www.HepcoMotion.com/pdu2datauk)) are compatible with the PDU2M. Other items including motors, drives, axis connection kits, drive shafts and other compatible axes and components are available from Hepco.

## Example 3-axis system

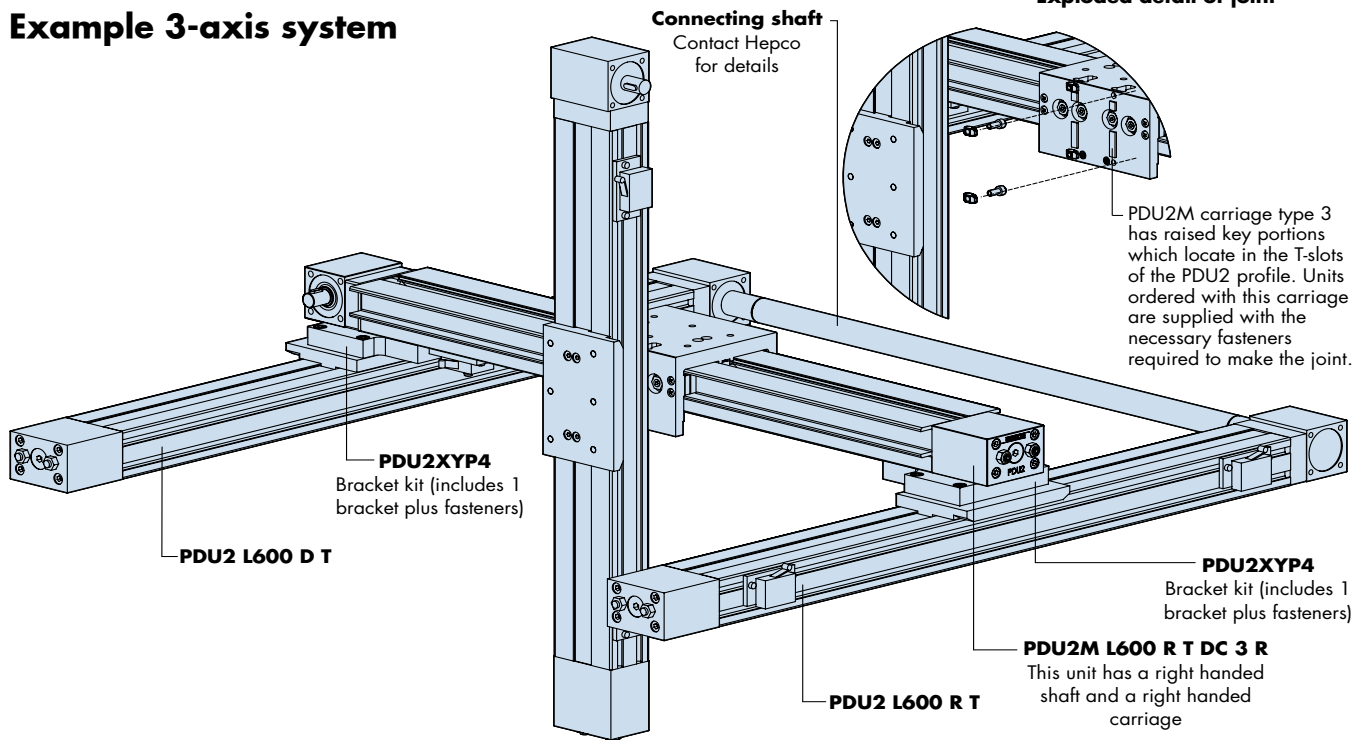

**HepcoMotion®**

Lower Moor Business Park, Tiverton Way, Tiverton, Devon, England, EX16 6TG

Tel: +44(0)1884 257000 Fax: +44(0)1884 243500

Email: [sales@hepcotion.com](mailto:sales@hepcotion.com)

[www.HepcoMotion.com](http://www.HepcoMotion.com)

CATALOGUE No. PDU2M 03 UK © 2011 Hepco Slide Systems Ltd.

Reproduction in whole or in part without prior authorisation from Hepco is prohibited. Although every effort has been made to ensure the accuracy of the information in this catalogue, Hepco cannot accept liability for any omissions or errors. Hepco reserves the right to make alterations to the product resulting from technical developments.

Many Hepco products are protected by: Patents, Copyright, Design Right or Registered Design. Infringement is strictly prohibited and may be challenged in law.

The customers attention is drawn to the following clause in Hepco's conditions of sale:

'It shall be the Customer's sole responsibility to ensure that goods supplied by Hepco will be suitable or fit for any particular application or purpose of the Customer, whether or not such application or purpose is known to Hepco. The customer will be solely responsible for any errors in, or omission from, any specifications or information the Customer provides. Hepco will not be obliged to verify whether such specifications or information are correct or sufficient for any application or purpose.

Hepco's full terms and conditions of sale are available on request and will apply to all quotations and contracts for the supply of goods detailed in this catalogue.